



P.O. BOX 31207
CLEVELAND, OHIO 44131

" The Super Savers "



ORDER
BY PHONE

TOLL FREE
1-800-222-1141

FAX: 216-524-5682

Ohio 1-800-338-5608

216-524-7100

**PUGMILL
TIPS**



**ARMS
(SHANKS)**

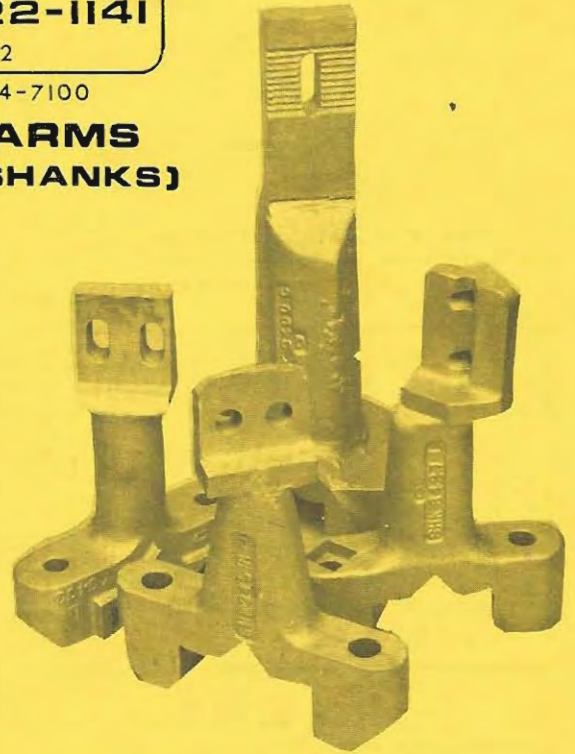

PUGMILL REPLACEMENT PARTS

For all makes.....
of ASPHALT PLANTS

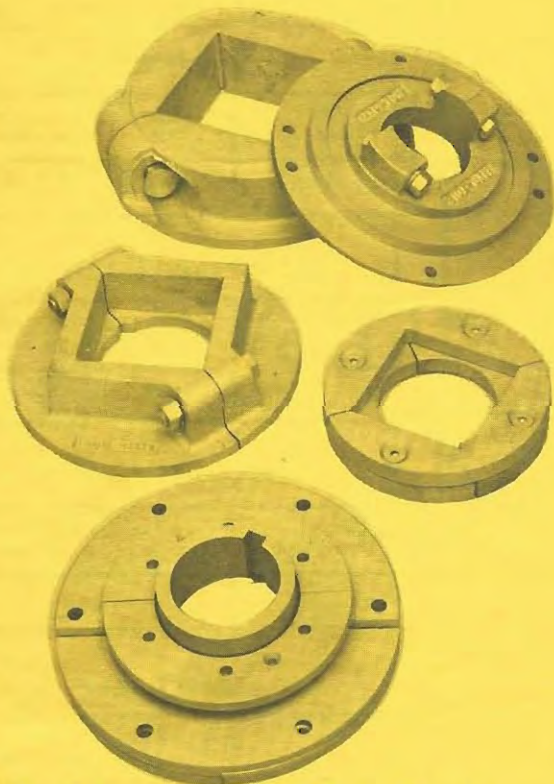

SEALS & COLLARS

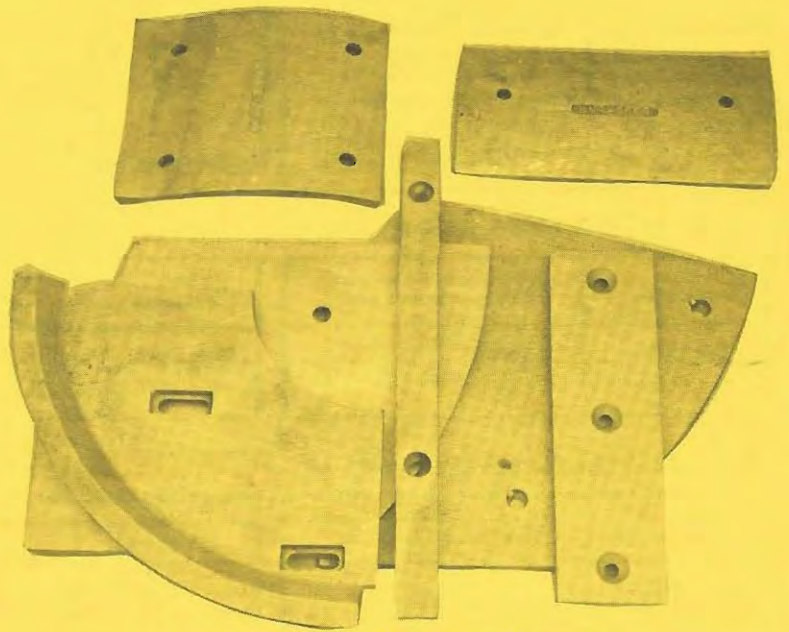

PUGMILL LINERS

"YOUR HEADQUARTERS FOR ASPHALT PLANT REPLACEMENT PARTS"



ORDER
BY PHONE

TOLL FREE
1-800-222-1141

Ohio 1-800-338-5608

FAX 216-524-5682

Telephone 216-524-7100



REPLACEMENT Mixer (Pugmill) TIPS

BARBER GREENE

C.P.I. PART NO.	REPLACEMENT FOR O.E.M. PART NO.
TPS-3514	A-3-3855-C (5284)
TPS-3516	A-3-3840-C (5273)
TPS-3517	A-3-1974-C (4467)
	A-3-1051-C
TPS-3518	A-3-4241-C
TPS-3534	A-3-2385-C (4664)
TPS-3566	A-3-2946-C
TPS-3575	A-3-3739-C (5191)
TPS-3577	A-3-3946-C

STANSTEEL

C.P.I. PART NO.	REPLACEMENT FOR O.E.M. PART NO.
TPS-3530-R	10523 (B-9248-R)
TPS-3530-L	10524 (B-9248-L)
TPS-3531-R	10521 (4631H-B1-R)
TPS-3531-L	10522 (4631H-B1-L)
TPS-3532-R	10513 (C-9500-R)
TPS-3532-L	10514 (C-9500-L)
TPS-3533-R	10511 (3456-R)
TPS-3533-L	10512 (3456-L)
TPS-3580-R	10532
TPS-3580-L	10531

MADSEN

C.P.I. PART NO.	REPLACEMENT FOR O.E.M. PART NO.
TPS-3555-R	25-41-Y
TPS-3555-L	25-41-Z
TPS-3592-R	25-238-A
TPS-3592-L	25-238-B
TPS-3593-R	25-112-G
TPS-3593-L	25-112-H
TPS-3509-R	25-244-A
TPS-3509-L	25-244-B
TPS-3510-R	25-374-A
TPS-3510-L	25-374-B

H & B

C.P.I. PART NO.	REPLACEMENT FOR O.E.M. PART NO.
TPS-3522	450-2-02084
TPS-3525	450-2-02480 (4-006362)
TPS-3527	450-2-02467 (4-006015)
TPS-3529	450-2-16852 (4-006121)

CEDARAPIDS

C.P.I. PART NO.	REPLACEMENT FOR O.E.M. PART NO.
TPS-3511	5011-B04A
	5011-B04B
TPS-3512	5073-G18C
	5073-G18D
TPS-3568	5011BD19
TPS-3513-R	4301-A11
TPS-3513-L	4301-A11-01

CMI (SIMPLICITY)

C.P.I. PART NO.	REPLACEMENT FOR O.E.M. PART NO.
TPS-3504	F-553 (G-553) (305-00055-0000)
TPS-3505	F-213 (G-213) (305-00015-0000)

MCCARTER

C.P.I. PART NO.	REPLACEMENT FOR O.E.M. PART NO.
TPS-3500	(4000/5000/6000)
TPS-3501	575000 (M-1017)

**TIP BOLTS
Available**

ASTEC

C.P.I. PART NO.	REPLACEMENT FOR O.E.M. PART NO.
TPS-3529	P-1002

LITTLEFORD

C.P.I. PART NO.	REPLACEMENT FOR O.E.M. PART NO.
TPS-3506	3731944
TPS-3546	PM-11097

CUMMER

C.P.I. PART NO.	REPLACEMENT FOR O.E.M. PART NO.
TPS-3503	1854 (Alt.)
TPS-3502	2025 (2566-048)

CUSTOM-BUILT

C.P.I. PART NO.	REPLACEMENT FOR O.E.M. PART NO.
TPS-3527	1037 (4-006362)

WHITE

C.P.I. PART NO.	REPLACEMENT FOR O.E.M. PART NO.
TPS-3522	2084

IROQUOIS (POSEY)

C.P.I. PART NO.	REPLACEMENT FOR O.E.M. PART NO.
TPS-3585	4362
TPS-3589	1540
TPS-3588	10009 (4250)

PIONEER

C.P.I. PART NO.	REPLACEMENT FOR O.E.M. PART NO.
TPS-3547	G-230
TPS-3548	G-623
TPS-3549	G-00619

WYLIE

C.P.I. PART NO.	REPLACEMENT FOR O.E.M. PART NO.
TPS-3586	6300154 (28-44-8A)

CONSTRUCTION PARTS INC.®



ORDER
BY PHONE

TOLL FREE
1-800-222-1141

FAX: 216-524-5682

Ohio 1-800-338-5608

216-524-7100

MIXER SHANKS (Arms)



BARBER GREENE

C.P.I. PART No.	REPLACEMENT FOR O.E.M. PART No.
SHK-3400-B	AB-3-3854-C D-3-3854-C
SHK-3400-C	AC-3-3854-C E-3-3854-C
SHK-3401-E	A-1-3-3854-C B-3-3854-C
SHK-3401-D	AA-1-3-3854-C C-3-3854-C
SHK-3470-AA	AA-3-1051-C E-3-1051-C (3473)
SHK-3470-AB	AB-3-1051-C F-3-1051-C (3474)
SHK-3475	A-3-4125-C B-3-4125-C (5452)
SHK-3476	AA-3-4125-C C-3-4125-C (5451)
SHK-3481-C	A-3-1580-C B-3-1580-C (4219)
SHK-3481-E	AA-3-1580-C D-3-1580-C (4220)
SHK-3483-A SHK-3483-AA	A-3-3740-C AA-3-3740-C
SHK-3484-A	A-3-2392-C B-3-2392-C (4668)
SHK-3484-AA	AA-3-2392-C D-3-2392-C (4669)
SHK-3485-A	A-3-3841-C B-3-3841-C (5274)
SHK-3485-AA	AA-3-3841-C C-3-3841-C (5275)
SHK-3490-A SHK-3490-AA	For B/G Model #824/#840

CEDARAPIDS

C.P.I. PART No.	REPLACEMENT FOR O.E.M. PART No.
SHK-3411	5033 G08 04
SHK-3412	5073 G12 04A
SHK-3495	5071 G12 04A
SHK-3809	5031 G30 04

BARBER GREENE

C.P.I. PART No.	REPLACEMENT FOR O.E.M. PART No.
SHK-3486-A	A-3-2635-W
SHK-3486-B	B-3-2635-W
SHK-3486-C	C-3-2635-W
SHK-3486-D	D-3-2635-W
SHK-3489-A	A-3-2342-W (4644)
SHK-3489-C	C-3-2342-W (4645)

H & B

C.P.I. PART No.	REPLACEMENT FOR O.E.M. PART No.
SHK-3446-R	450-2-02103
SHK-3446-L	450-2-02104
SHK-3800-R	450-2-02437
SHK-3800-L	450-2-02438
SHK-3422-R	450-2-02466
SHK-3422-L	450-2-02468
SHK-3423-R	450-2-06408 (4-006120)
SHK-3423-L	450-2-06409 (4-006247)

MCCARTER

C.P.I. PART No.	REPLACEMENT FOR O.E.M. PART No.
SHK-3433-R	413000 M-205 M-1011-B
SHK-3433-L	413500 M-206 M-1011-A
SHK-3434-R	415000 M-1000-A
SHK-3434-L	415500 M-1000-B

PIONEER

C.P.I. PART No.	REPLACEMENT FOR O.E.M. PART No.
SHK-3802	G-00455
SHK-3457	G-00621

LITTLEFORD

C.P.I. PART No.	REPLACEMENT FOR O.E.M. PART No.
SHK-3426-CW	3731727
SHK-3426-CCW	3731725

STANSTEEL

C.P.I. PART No.	REPLACEMENT FOR O.E.M. PART No.
SHK-3439-R	11024 B3000-401-143 PC-33-A
SHK-3439-L	11025 B3000-401-144 PC-33-B
SHK-3440-R	11030 401127 C-9511-R
SHK-3440-L	11031 401128 C-9511-L
SHK-3442-R	11048 401131 401133 C-9439-R
SHK-3442-L	11047 401132 401134 C-9439-L
SHK-3449-R	11022 MD-447-AR
SHK-3449-L	11023 MD-447-AL
SHK-3451-R	11026 4090-ER
SHK-3451-L	11027 4090-EL
SHK-3459-R	11020 MD-677-ER
SHK-3459-L	11021 MD-677-EL

MADSEN

C.P.I. PART No.	REPLACEMENT FOR O.E.M. PART No.
SHK-3431-R	25-30-G
SHK-3431-L	25-30-H
SHK-3430-R	25-273-A
SHK-3430-L	25-273-B
SHK-3428-R	25-243-A
SHK-3428-L	25-243-B
SHK-3427-R	25-285-A
SHK-3427-L	25-285-B
SHK-3429-R	25-373-A
SHK-3429-L	25-373-B

SHANK BOLTS- Available

"YOUR HEADQUARTERS FOR ASPHALT PLANT REPLACEMENT PARTS"

C O N S T R U C T I O N P A R T S I N C. ®



ORDER
BY PHONE

TOLL FREE
1-800-222-1141

FAX: 216-524-5682

Ohio 1-800-338-5608

216-524-7100

MIXER SHAFT COLLARS & SEALS

BARBER GREENE

C.P.I. PART No.	REPLACEMENT FOR O.E.M. PART No.
MXP-7118	B-3-3672-C Hub
MXP-7168	D-3-3672-C Hub
MXP-7169	E-3-3672-C Hub
MXP-7245	B-3-2617 Hub
MXP-7246	C-3-2617 Hub

C.P.I. PART No.	REPLACEMENT FOR O.E.M. PART No.
MXP-7119	A-3-2618 Ring
MXP-7120	A-3-2627 Ring
MXP-7121	A-3-2616 Ring
MXP-7122	A-3-2615 Ring
MXP-7123	A-3-2619 Ring

C.P.I. PART No.	REPLACEMENT FOR O.E.M. PART No.
MXP-7171-A	A-17-322 Shim
MXP-7171-B	B-17-322 Shim
MXP-7171-C	C-17-322 Shim

STANSTEEL

C.P.I. PART No.	REPLACEMENT FOR O.E.M. PART No.
MXP-7020	10012
MXP-7021	10015
MXP-7022	10014
MXP-7140	10010/447-C
MXP-7249	10013

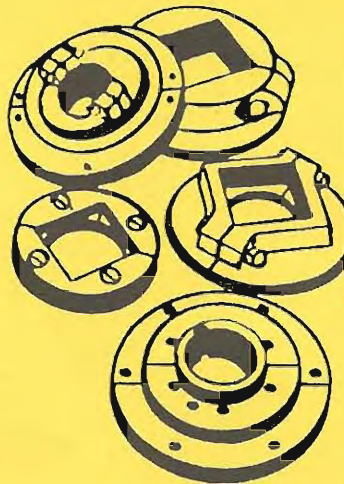

CMi (SIMPLICITY)

C.P.I. PART No.	REPLACEMENT FOR O.E.M. PART No.
MXP-7164	F-601 136-00050-0000
MXP-7198	F-602 136-00051-0000

MADSEN

C.P.I. PART No.	REPLACEMENT FOR O.E.M. PART No.
MXP-7004	25-284-A
MXP-7005	25-318-A
MXP-7006	252-MA-649
MXP-7007	25-131-G
MXP-7153	25-81-C & G
MXP-7154	25-81-D

MCCARTER

C.P.I. PART No.	REPLACEMENT FOR O.E.M. PART No.
MXP-7009	422000 - 3/8" Thk. End Liner
MXP-7010	422000 - 5/8" Thk. End Liner
MXP-7011	424000 424500
MXP-7176	423500 (M-1008)
MXP-7215	424500 (M1033)
MXP-7216	425500 (M1033)

H & B

C.P.I. PART No.	REPLACEMENT FOR O.E.M. PART No.
MXP-7012	450-6-02489
MXP-7013	450-6-02490
MXP-7014	450-6-02460 (1-006190)
MXP-7015	450-6-02461 (1-006189)
MXP-7016	450-6-06406 (1-006028)
MXP-7017	450-6-02569 (1-006027)

LITTLEFORD

C.P.I. PART No.	REPLACEMENT FOR O.E.M. PART No.
MXP-7025	3731403 (PHH220082)
MXP-7026	3721728

IROQUOIS (POSEY)

C.P.I. PART No.	REPLACEMENT FOR O.E.M. PART No.
MXP-7185	4008
MXP-7186	10001
MXP-7193	4363

"YOUR HEADQUARTERS FOR ASPHALT PLANT REPLACEMENT PARTS"



ORDER BY PHONE **TOLL FREE 1-800-222-1141**
 Ohio 1-800-338-5608
 FAX 216-524-5682 Telephone 216-524-7100



PUGMILL LINERS

AVAILABLE REPLACEMENT PARTS FOR **BARBER-GREENE** PLANTS

(Old Barber-Greene 4-Digit Part Nos.)

C.P.I. PART No.	REPLACEMENT FOR O.E.M. PART No.	C.P.I. PART No.	REPLACEMENT FOR O.E.M. PART No.	C.P.I. PART No.	REPLACEMENT FOR O.E.M. PART No.
LNR-2578-A	4709	LNR-2647-A	4755	LNR-2457-A	5214
LNR-2578-AA	4710	LNR-2647-AA	4756	LNR-2457-AA	5215
LNR-2460-A	4711	LNR-2462-A	4808	LNR-2459-A	5247
LNR-2460-AA	4712	LNR-2462-AA	4809	LNR-2459-AA	5248
LNR-2461-A	4713	LNR-2463-A	4810	LNR-2515-A	5263
LNR-2461-AA	4714	LNR-2463-AA	4811	LNR-2516-A	5264
LNR-2579-A	4715	LNR-2583-A	4812	LNR-2628-A	5265
LNR-2579-AA	4716	LNR-2458-A	4813	LNR-2471-A	5330
LNR-2580-A	4717	LNR-2584-A	4814	LNR-2471-AA	5331
LNR-2581-A	4718	LNR-2731-A	4817	LNR-2472-A	5332
LNR-2582-A	4719	LNR-2731-AA	4818	LNR-2472-AA	5333
LNR-2582-AA	4720	LNR-2732-A	4819	LNR-2597-A	5428
LNR-2559-A	4721	LNR-2732-AA	4820	LNR-2669-A	5429
LNR-2559-AA	4722	LNR-2723-A	4821	LNR-2598-A	5433
LNR-2560-A	4723	LNR-2723-AA	4885	LNR-2598-AA	5434
LNR-2560-AA	4724	LNR-2735-A	4822	LNR-2599-A	5435
LNR-2455-A1	4725	LNR-2736-A	4823	LNR-2599-AA	5436
LNR-2455-A2	4725	LNR-2585-A	4824	LNR-2602-A	5437
LNR-2577-A	4725	LNR-2586-A	4825	LNR-2602-AA	5438
LNR-2733-A	4728	LNR-2587-A	4828	LNR-2593-A	5439
LNR-2733-AA	4729	LNR-2587-AA	4829	LNR-2593-AA	5440
LNR-2681-A	4730	LNR-2588-A	4830	LNR-2594-A	5441
LNR-2681-AA	4731	LNR-2588-AA	4831	LNR-2594-AA	5442
LNR-2682-A	4732	LNR-2589-A	4832	LNR-2595-A	5443
LNR-2682-AA	4733	LNR-2589-AA	4833	LNR-2595-AA	5444
LNR-2683-A	4734	LNR-2590-A	4834	LNR-2596-A	5445
LNR-2683-AA	4735	LNR-2590-AA	4835	LNR-2596-AA	5446
LNR-2734-A	4736	LNR-2456-A	4873	LNR-2603-A	5448
LNR-2638-A	4748	LNR-2724-A	4874	LNR-2604-A	5449
LNR-2638-AA	4749	LNR-2591-A	4886		
LNR-2637-A	4750	LNR-2591-AA	4887		
LNR-2637-AA	4751	LNR-2470-A	4991		
LNR-2646-A	4753	LNR-2470-AA	4992		
LNR-2646-AA	4754				

LINER BOLTS Available



ORDER BY PHONE TOLL FREE 1-800-222-1141
 Ohio 1-800-338-5608
 Telephone 216-524-7100
 FAX 216-524-5682

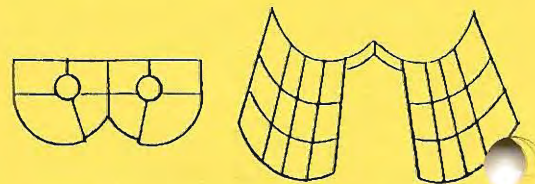

PUGMILL LINERS

AVAILABLE REPLACEMENT PARTS FOR BARBER-GREENE PLANTS

C.P.I. PART No.	REPLACEMENT FOR O.E.M. PART No.	C.P.I. PART No.	REPLACEMENT FOR O.E.M. PART No.	C.P.I. PART No.	REPLACEMENT FOR O.E.M. PART No.
LNR-2578-A	A-3-2591-C	LNR-2647-A	A-3-2658-C	LNR-2591-A	A-3-2964-C
LNR-2578-AA	AA-3-2591-C	LNR-2647-AA	AA-3-2658-C	LNR-2591-AA	AA-3-2964-C
LNR-2460-A	A-3-2593-C	LNR-2462-A	A-3-2837-C	LNR-2470-A	A-3-3299-C
LNR-2460-AA	AA-3-2593-C	LNR-2462-AA	AA-3-2837-C	LNR-2470-AA	AA-3-3299-C
LNR-2461-A	A-3-2594-C	LNR-2463-A	A-3-2838-C	LNR-2457-A	A-3-3762-C
LNR-2461-AA	AA-3-2594-C	LNR-2463-AA	AA-3-2838-C	LNR-2457-AA	AA-3-3762-C
LNR-2579-A	A-3-2602-C	LNR-2583-A	A-3-2839-C	LNR-2459-A	A-3-3804-C
LNR-2579-AA	AA-3-2602-C	LNR-2458-A	A-3-2840-C	LNR-2459-AA	AA-3-3804-C
LNR-2580-A	A-3-2603-C	LNR-2584-A	A-3-2841-C	LNR-2515-A	A-3-3825-C
LNR-2581-A	A-3-2604-C	LNR-2584-A	B-3-2841-C	LNR-2515-A	A-3-3826-C
LNR-2582-A	A-3-2605-C	LNR-2731-A	A-3-2846-C	LNR-2628-A	A-3-3827-C
LNR-2582-AA	AA-3-2605-C	LNR-2731-AA	AA-3-2846-C	LNR-2464-A	A-3-3836-C
LNR-2559-A	A-3-2606-C	LNR-2732-A	A-3-2847-C	LNR-2644-A	A-3-3914-C
LNR-2559-AA	AA-3-2606-C	LNR-2732-AA	AA-3-2847-C	LNR-2644-AA	AA-3-3914-C
LNR-2560-A	A-3-2607-C	LNR-2723-A	A-3-2848-C	LNR-2471-A	A-3-3915-C
LNR-2560-AA	AA-3-2607-C	LNR-2723-AA	AA-3-2848-C	LNR-2471-AA	AA-3-3915-C
LNR-2455-A1	A-3-2608-C	LNR-2735-A	A-3-2849-C	LNR-2472-A	A-3-3916-C
LNR-2455-A2	A-3-2608-C	LNR-2736-A	A-3-2850-C	LNR-2472-AA	AA-3-3916-C
LNR-2577-A	A-3-2608-C	LNR-2585-A	A-3-2853-C	LNR-2684-A	A-3-4019-C
LNR-2733-A	A-3-2628-C	LNR-2585-A	B-3-2853-C	LNR-2684-AA	AA-3-4019-C
LNR-2733-AA	AA-3-2628-C	LNR-2586-A	A-3-2854-C	LNR-2597-A	A-3-4034-C
LNR-2681-A	A-3-2629-C	LNR-2587-A	A-3-2857-C	LNR-2669-A	A-3-4036-C
LNR-2681-AA	AA-3-2629-C	LNR-2587-A	B-3-2857-C	LNR-2669-A	B-3-4036-C
LNR-2682-A	A-3-2630-C	LNR-2587-AA	AA-3-2857-C	LNR-2675-A	A-3-4037-C
LNR-2682-AA	AA-3-2630-C	LNR-2587-AA	C-3-2857-C	LNR-2615-A	A-3-4038-C
LNR-2683-A	A-3-2631-C	LNR-2588-A	A-3-2858-C	LNR-2670-A	A-3-4039-C
LNR-2683-AA	AA-3-2631-C	LNR-2588-AA	AA-3-2858-C	LNR-2670-A	B-3-4039-C
LNR-2734-A	A-3-2632-C	LNR-2589-A	A-3-2859-C	LNR-2598-A	A-3-4040-C
LNR-2638-A	A-3-2653-C	LNR-2589-AA	AA-3-2859-C	LNR-2598-AA	AA-3-4040-C
LNR-2638-AA	AA-3-2653-C	LNR-2590-A	A-3-2860-C	LNR-2599-A	A-3-4041-C
LNR-2637-A	A-3-2654-C	LNR-2590-AA	AA-3-2860-C	LNR-2599-AA	AA-3-4041-C
LNR-2637-AA	AA-3-2654-C	LNR-2456-A	A-3-2916-C	LNR-2602-A	A-3-4042-C
LNR-2646-A	A-3-2657-C	LNR-2724-A	A-3-2922-C	LNR-2602-AA	AA-3-4042-C
LNR-2646-AA	AA-3-2657-C				

LINER BOLTS - Available

"YOUR HEADQUARTERS FOR ASPHALT PLANT REPLACEMENT PARTS"



ORDER
BY PHONE

TOLL FREE
1-800-222-1141

Ohio 1-800-338-5608

FAX 216-524-5682

Telephone 216-524-7100

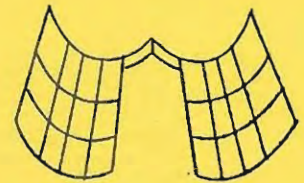
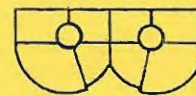

PUGMILL LINERS

AVAILABLE REPLACEMENT PARTS FOR **BARBER-GREENE** PLANTS

C.P.I. PART No.	REPLACEMENT FOR O.E.M. PART No.
LNR-2593-A	A-3-4043-C
LNR-2593-AA	AA-3-4043-C
LNR-2594-A	A-3-4044-C
LNR-2594-AA	AA-3-4044-C
LNR-2595-A	A-3-4045-C
LNR-2595-AA	AA-3-4045-C
LNR-2596-A	A-3-4046-C
LNR-2596-AA	AA-3-4046-C
LNR-2603-A	A-3-4048-C
LNR-2604-A	A-3-4049-C
LNR-2480-A	A-3-4184-C
LNR-2480-A	B-3-4184-C
LNR-2480-AA	AA-3-4184-C
LNR-2480-AA	C-3-4184-C
LNR-2469-A	A-3-4320-C
LNR-2469-AA	AA-3-4320-C
LNR-2474-A	A-3-4321-C
LNR-2474-AA	AA-3-4321-C
LNR-2606-A	A-3-4322-C
LNR-2606-AA	AA-3-4322-C
LNR-2467-A	A-3-4323-C
LNR-2467-AA	AA-3-4323-C
LNR-2466-A	A-3-4324-C
LNR-2466-AA	AA-3-4324-C
LNR-2465-A	A-3-4325-C
LNR-2465-AA	AA-3-4325-C
LNR-2475-A	A-3-4331-C
LNR-2475-AA	AA-3-4331-C
LNR-2476-A	A-3-4332-C
LNR-2476-AA	AA-3-4332-C
LNR-2600-A	A-3-4337-C
LNR-2600-AA	AA-3-4337-C
LNR-2601-A	A-3-4338-C
LNR-2601-AA	AA-3-4338-C
LNR-2612-A	A-3-4357-C
LNR-2612-AA	AA-3-4357-C

C.P.I. PART No.	REPLACEMENT FOR O.E.M. PART No.
LNR-2613-A	A-3-4358-C
LNR-2613-AA	AA-3-4358-C
LNR-2630-A	A-3-4360-C
LNR-2631-A	A-3-4361-C
LNR-2632-A	A-3-4362-C
LNR-2639-A	A-3-4424-C
LNR-2639-AA	AA-3-4424-C
LNR-2640-A	A-3-4425-C
LNR-2640-AA	AA-3-4425-C
LNR-2629-A	A-3-4585-C
LNR-2629-AA	AA-3-4585-C
LNR-2645-A1	A-3-4586-C
LNR-2645-A2	AA-3-4586-C
LNR-2624-A	A-3-4587-C
LNR-2624-AA	AA-3-4587-C
LNR-2625-A	A-3-4588-C
LNR-2625-AA	AA-3-4588-C
LNR-2642-A	A-3-4589-C
LNR-2642-AA	AA-3-4589-C
LNR-2643-A	A-3-4590-C
LNR-2643-AA	AA-3-4590-C
LNR-2626-A	A-3-4591-C
LNR-2626-AA	AA-3-4591-C
LNR-2627-A	A-3-4592-C
LNR-2627-AA	AA-3-4592-C
LNR-2706-A	A-3-4595-C
LNR-2706-AA	AA-3-4595-C
LNR-2707-A	A-3-4596-C
LNR-2707-AA	AA-3-4596-C
LNR-2716-A	A-3-4597-C
LNR-2716-AA	AA-3-4597-C
LNR-2717-A	A-3-4598-C
LNR-2717-AA	AA-3-4598-C

LINER BOLTS - Available



ORDER BY PHONE
TOLL FREE 1-800-222-1141
Ohio 1-800-332-5608
FAX 216-524-5682 Telephone 216-24-7100

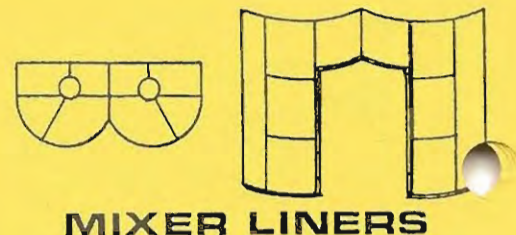

MIXER LINERS

AVAILABLE REPLACEMENT PARTS FOR H & B PLANTS

C.P.I. PART No.	REPLACEMENT FOR O.E.M. PART No.	C.P.I. PART No.	REPLACEMENT FOR O.E.M. PART No.	C.P.I. PART No.	REPLACEMENT FOR O.E.M. PART No.
LNR-2415	2000# Mixer	LNR-2193	450-2-06033	LNR-2210	450-2-16482 (3-005638)
LNR-2424	2000# Mixer	LNR-2194	450-2-06038	LNR-2212	450-2-16484 (3-005642)
LNR-2190	450-2-02481	LNR-2223	450-2-06449	LNR-2228	450-2-16486/87 (3-005637)
LNR-2191	450-2-02482	LNR-2570	450-2-06485	LNR-2213	450-2-16488 (3-005641)
LNR-2221	450-2-02484	LNR-2571	450-2-15048	LNR-2744	450-2-16489
LNR-2196	450-2-02536	LNR-2572	450-2-15049	LNR-2279	450-2-16490 (3-005566)
LNR-2197	450-2-02537	LNR-2573	450-2-15050	LNR-2505	450-2-16490 (3-005566)
LNR-2235	450-2-02545-R	LNR-2225	450-2-16321	LNR-2506	450-2-16490 (3-005566)
LNR-2236	450-2-02545-R	LNR-2206	450-2-16323	LNR-2280	450-2-16491 (3-005577)
LNR-2237	450-2-02545-L (14512)	LNR-2204	450-2-16340	LNR-2507	450-2-16491 (3-005577)
LNR-2238	450-2-02545-L (14512)	LNR-2207	450-2-16341	LNR-2508	450-2-16491 (3-005577)
LNR-2233	450-2-02546-R	LNR-2655	450-2-16342 (3-005708)	LNR-2287	450-2-16492 (3-005564)
LNR-2234	450-2-02546-L (14513)	LNR-2656	450-2-16342 (3-005708)	LNR-2288	450-2-16492 (3-005564)
LNR-2222	450-2-02548	LNR-2657	450-2-16343 (3-005709)	LNR-2289	450-2-16493 (3-005565)
LNR-2195	450-2-02552	LNR-2658	450-2-16343 (3-005709)	LNR-2290	450-2-16493 (3-005565)
LNR-2189	450-2-02576	LNR-2205	450-2-16349	LNR-2745	450-2-16537
LNR-2245	450-2-02668-R	LNR-2654	450-2-16365 (3-005706)	LNR-2215	450-2-16538 (3-005639)
LNR-2246	450-2-02668-L (14514)	LNR-2653	450-2-16366 (3-005707)	LNR-2219	450-2-16540
LNR-2251	450-2-02668-R	LNR-2208	450-2-16415 (3-005715)	LNR-2224	450-2-16861
LNR-2252	450-2-02668-R	LNR-2227	450-2-16416	LNR-2226	450-2-16862 (4-006015)
LNR-2253	450-2-02668-L (14514)	LNR-2209	450-2-16417 (3-005714)	LNR-2229	450-2-16863 (3-006116)
LNR-2254	450-2-02668-L (14514)	LNR-2202	450-2-16448		
LNR-2648	450-2-02669-R	LNR-2201	450-2-16451		
LNR-2649	450-2-02669-R	LNR-2255	450-6-16453		
LNR-2650	450-2-02669-L	LNR-2256	450-6-16454		
LNR-2651	450-2-02669-L	LNR-2257	450-6-16455		
LNR-2198	450-2-02768	LNR-2258	450-6-16456		
LNR-2192	450-2-02769	LNR-2225	450-2-16463		
LNR-2200	450-2-03681	LNR-2203	450-2-16468		
LNR-2199	450-2-03682				

LINER BOLTS - Available

"YOUR HEADQUARTERS FOR ASPHALT PLANT REPLACEMENT PARTS"



ORDER BY PHONE **TOLL FREE**
1-800-222-1141
Ohio 1-800-338-5608
 FAX 216-524-5682 Telephone 216-524-7100

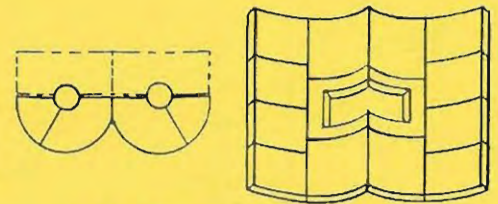

MIXER LINERS

AVAILABLE REPLACEMENT PARTS FOR CEDARAPIDS PLANTS

C.P.I. PART No.	REPLACEMENT FOR O.E.M. PART No.	C.P.I. PART No.	REPLACEMENT FOR O.E.M. PART No.	C.P.I. PART No.	REPLACEMENT FOR O.E.M. PART No.
LNR-2168	5031G02	LNR-2171	5033GC10	LNR-2180-L1	5073G10
LNR-2156	5031G10A	LNR-2153	5033GE04	LNR-2180-L2	5073G10
LNR-2157	5031G11A	LNR-2160	5033GE05	LNR-2146	5073G11A
LNR-2158	5031G12A	LNR-2155	5033GE06	LNR-2167	5073G17
LNR-2185-R1	5031G13	LNR-2546-L1	5034G12	LNR-2757	Model "E" 4/5,000# Gate Liner
LNR-2185-R2	5031G13	LNR-2546-L2	5034G12	LNR-2758	4300-H17G
LNR-2186-L1	5031G14	LNR-2547-R1	5034G13	LNR-2759	4300-H17H
LNR-2186-L2	5031G14	LNR-2547-R2	5034G13	LNR-2760	4300-H18C
LNR-2154	5031GE05	LNR-2132	5071G06	LNR-2761-L1	4300-A2402-LH
LNR-2159	5031GE06A	LNR-2133	5071G07	LNR-2761-L2	4300-A2402-LH
LNR-2161-A01	5031GE07A01	LNR-2134	5071G07A	LNR-2761-R1	4300-A2401-RH
LNR-2161-A02	5031GE07A02	LNR-2135	5071G07B	LNR-2761-R2	4300-A2401-RH
LNR-2161-B01	5031GE07B01	LNR-2136	5071G08	LNR-2762	S-731/ HM-123
LNR-2161-B02	5031GE07B02	LNR-2175-R1	5071G09	LNR-2763	S-730/ HM-122
LNR-2169	5031GE13A	LNR-2175-R2	5071G09	LNR-2764	Model "E" 3,000# Gate Liner
LNR-2150	5033G04	LNR-2176-L1	5071G10	LNR-2765-1	S-730/ HM-122
LNR-2151	5033G05	LNR-2176-L2	5071G10	LNR-2765-2	S-730/ HM-122
LNR-2152	5033G06	LNR-2137	5071G11B		
LNR-2170	5033G07	LNR-2138	5071G11C		
LNR-2181-L1	5033G16	LNR-2139	5071G11D		
LNR-2181-L2	5033G16	LNR-2165	5071G17A		
LNR-2182-R1	5033G17	LNR-2143	5073G06		
LNR-2182-R2	5033G17	LNR-2144	5073G07		
LNR-2147	5033GC07	LNR-2145	5073G08		
LNR-2148	5033GC08	LNR-2179-R1	5073G09		
LNR-2149	5033GC09	LNR-2179-R2	5073G09		

LINER BOLTS Available

"YOUR HEADQUARTERS FOR ASPHALT PLANT REPLACEMENT PARTS"



ORDER BY PHONE
TOLL FREE 1-800-222-1141
Ohio 1-800-338-5608
FAX 216-524-5682 Telephone 216-524-7100

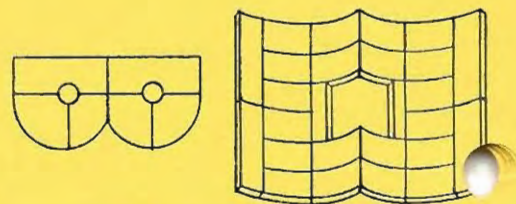

MIXER LINERS

AVAILABLE REPLACEMENT PARTS FOR **STANSTEEL** PLANTS

C.P.I. PART No.	REPLACEMENT FOR O.E.M. PART No.	C.P.I. PART No.	REPLACEMENT FOR O.E.M. PART No.	C.P.I. PART No.	REPLACEMENT FOR O.E.M. PART No.
LNR-2534	4081-FB	LNR-2448	01051	LNR-2377-1	12074
LNR-2535	4081-FC	LNR-2449	01052	LNR-2377-2	12075
LNR-2536	4081-FD	LNR-2636	01053	LNR-2534	401420
LNR-2358	4090-A	LNR-2452	01054	LNR-2535	401921
LNR-2359	4090-B	LNR-2451	01055	LNR-2536	401922
LNR-2392	01016	LNR-2450	01056	LNR-2352	401928
LNR-2390	01017	LNR-2534	12013	LNR-2353	401929
LNR-2388	01018	LNR-2535	12014	LNR-2360	401936
LNR-2391	01019	LNR-2536	12015	LNR-2361	401937
LNR-2389	01020	LNR-2347	12016	LNR-2358	401938
LNR-2387	01021	LNR-2346	12017	LNR-2359	401939
LNR-2397	01023	LNR-2350	12018	LNR-2377-1	401940
LNR-2395	01024	LNR-2352	12019	LNR-2377-2	401941
LNR-2398	01025	LNR-2353	12020	LNR-2364	401942
LNR-2393	01026	LNR-2358	12021	LNR-2365	401943
LNR-2396	01027	LNR-2359	12022	LNR-2362	401944
LNR-2394	01028	LNR-2362	12025	LNR-2363	401945
LNR-2356	01029	LNR-2363	12026	LNR-2366	401946
LNR-2402	01030	LNR-2366	12027	LNR-2721	401947
LNR-2404	01031	LNR-2349	12034	LNR-2722	401948
LNR-2400	01032	LNR-2348	12035	LNR-2368	401949
LNR-2401	01033	LNR-2355	12036	LNR-2369	401950
LNR-2403	01034	LNR-2354	12037	LNR-2370	401951
LNR-2399	01035	LNR-2360	12038	LNR-2714-A	401952
LNR-2357	01036	LNR-2361	12039	LNR-2714-B	401953
LNR-2634	01037	LNR-2368	12042	LNR-2371	401954
LNR-2441	01038	LNR-2369	12043	LNR-2372	401955
LNR-2440	01039	LNR-2370	12044	LNR-2373	401956
LNR-2633	01040	LNR-2364	12048	LNR-2355	401965
LNR-2442	01041	LNR-2365	12049	LNR-2354	401966
LNR-2439	01042	LNR-2714-A	12064	LNR-2443	500250
LNR-2635	01044	LNR-2714-B	12065	LNR-2444	500251
LNR-2447	01045	LNR-2371	12066	LNR-2635	500252
LNR-2443	01046	LNR-2372	12067	LNR-2446	500253
LNR-2446	01047	LNR-2373	12068	LNR-2447	500254
LNR-2445	01048	LNR-2721	12071	LNR-2445	500255
LNR-2444	01049	LNR-2722	12072	LNR-2449	500257

LINER BOLTS - Available

"YOUR HEADQUARTERS FOR ASPHALT PLANT REPLACEMENT PARTS"



ORDER BY PHONE **TOLL FREE 1-800-222-1141**
 Ohio 1-800-338-5608
 FAX 216-524-5682 Telephone 216-524-7100

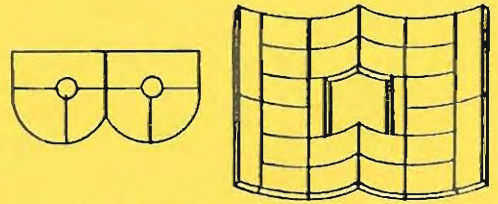

MIXER LINERS

AVAILABLE REPLACEMENT PARTS FOR STANSTEEL PLANTS

C.P.I. PART No.	REPLACEMENT FOR O.E.M. PART No.	C.P.I. PART No.	REPLACEMENT FOR O.E.M. PART No.	C.P.I. PART No.	REPLACEMENT FOR O.E.M. PART No.
LNR-2448	500258	LNR-2350	4089-F1-C2-3	LNR-2530	B-9497-C
LNR-2452	500259	LNR-2352	4133-H-CL-1	LNR-2531	B-9497-D
LNR-2451	500260	LNR-2353	4133-H-CL-2	LNR-2351	C-9096-C
LNR-2450	500261	LNR-2355	4133-H-CL-3		C-9096-35C
LNR-2636	500262	LNR-2354	4133-H-CL-4	LNR-2718	C-95132-SB
LNR-2349	90219-A	LNR-2377-1	47-000-169-00-001	LNR-2368	D-90361-A
LNR-2348	90219-B	LNR-2714-A	47-000-171-001	LNR-2369	D-90361-B
LNR-2360	90223-A	LNR-2377-2	47-000-173-00-001	LNR-2370	D-90361-C
LNR-2361	90223-B	LNR-2714-B	47-000-176-001	LNR-2532	D-902170-A
LNR-2371	91540-A	LNR-2352	47-700-098-01-001	LNR-2533	D-902170-B
LNR-2372	91540-B	LNR-2356	47-700-099-01-001	LNR-2714-A	E-90092-A
LNR-2373	91540-C	LNR-2371	47-700-553-001	LNR-2714-B	E-90092-B
LNR-2347	4089-F1-C2-1	LNR-2372	47-700-554-001	LNR-2383-1	Gate Liner
LNR-2346	4089-F1-C2-2	LNR-2373	47-800-375-01	LNR-2383-2	Gate Liner

LINER BOLTS - Available

AVAILABLE REPLACEMENT PARTS FOR McCARTER PLANTS

C.P.I. PART No.	REPLACEMENT FOR O.E.M. PART No.	C.P.I. PART No.	REPLACEMENT FOR O.E.M. PART No.	C.P.I. PART No.	REPLACEMENT FOR O.E.M. PART No.
LNR-2674	16603	LNR-2623-R	527500 M-1035-B	LNR-2438	537500 M-1018-A
LNR-2044	514000	LNR-2623-L	527500 M-1035-C	LNR-2047	End Liner
LNR-2569	514000 Segmental Type	LNR-2028	533000	LNR-2568	End Liner
LNR-2043	516000	LNR-2029	533500	LNR-2688-A	End Liner
LNR-2592	517000	LNR-2030	534000	LNR-2688-B	
LNR-2671-R	526500	LNR-2031	534500	LNR-2688-C	
LNR-2671-L	526500	LNR-2032	535000	LNR-2039	Gate Liner 30" Lg.
LNR-2672-R	526550	LNR-2033	535500	LNR-2040	Gate Liner 33" Lg.
LNR-2672-L	526550	LNR-2437	537000 M-1013-A	LNR-2041	Gate Liner 36" Lg.
LNR-2622	527000 M-1035-A				

"YOUR HEADQUARTERS FOR ASPHALT PLANT REPLACEMENT PARTS"



ORDER BY PHONE TOLL FREE 1-800-222-1141
 Ohio 1-800-338-5608
 Telephone 216-524-7100
 FAX 216-524-5682

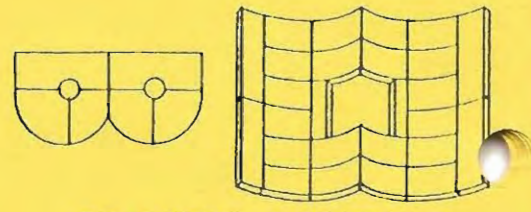

MIXER LINERS

AVAILABLE REPLACEMENT PARTS FOR MADSEN PLANTS

C.P.I. PART No.	REPLACEMENT FOR O.E.M. PART No.	C.P.I. PART No.	REPLACEMENT FOR O.E.M. PART No.	C.P.I. PART No.	REPLACEMENT FOR O.E.M. PART No.
LNR-2563	25-36-B	LNR-2001	25-253-B	LNR-2012	255-MF-242
LNR-2564	25-36-B	LNR-2002	25-253-C	LNR-2013	255-MG-242
LNR-2565	25-102-A	LNR-2003	25-260-A	LNR-2006	255-MH-242
LNR-2566-R	25-102-FF	LNR-2004	25-260-B	LNR-2000	255-MA-253
LNR-2567	25-102-GG	LNR-2005	25-260-C	LNR-2001	255-MB-253
LNR-2566-L	25-102-HH	LNR-2014	25-320-A	LNR-2002	255-MC-253
LNR-2720-L	25-127-C	LNR-2015	25-321-A	LNR-2003	255-MA-260
LNR-2720-R	25-127-D	LNR-2016	25-322-A	LNR-2004	255-MB-260
LNR-2719	25-127-E	LNR-2019	25-326-A	LNR-2005	255-MC-260
LNR-2420	25-128-A	LNR-2020	25-326-B	LNR-2014	255-MA-320
LNR-2421	25-128-B	LNR-2021	25-327-A	LNR-2015	255-MA-321
LNR-2561	25-191-A	LNR-2022	25-327-B	LNR-2016	255-MA-322
LNR-2562	25-191-A	LNR-2023	25-328-A	LNR-2019	255-MA-326
LNR-2007	25-242-A	LNR-2024	25-329-A	LNR-2020	255-MB-326
LNR-2008	25-242-B	LNR-2025	25-330-A	LNR-2021	255-MA-327
LNR-2009	25-242-C	LNR-2017	25-332-A	LNR-2022	255-MB-327
LNR-2012	25-242-D	LNR-2018	25-333-A	LNR-2023	255-MA-328
LNR-2011	25-242-E	LNR-2007	255-MA-242	LNR-2024	255-MA-329
LNR-2012	25-242-F	LNR-2008	255-MB-242	LNR-2025	255-MA-330
LNR-2013	25-242-G	LNR-2009	255-MC-242	LNR-2017	255-MA-332
LNR-2006	25-242-H	LNR-2010	255-MD-242	LNR-2018	255-MA-333
LNR-2000	25-253-A	LNR-2011	255-ME-242	LNR-2027	Gate Liner 8000# Mixer

AVAILABLE REPLACEMENT PARTS FOR ASTEC PLANTS

C.P.I. PART No.	REPLACEMENT FOR O.E.M. PART No.	C.P.I. PART No.	REPLACEMENT FOR O.E.M. PART No.	C.P.I. PART No.	REPLACEMENT FOR O.E.M. PART No.
LNR-2430	AT-C-122 P-1007	LNR-2433	AT-C-123 P-1008	LNR-2436	AT-C-121 P-1006 (5" Wide)
LNR-2431	AT-C-124 P-1009	LNR-2434	AT-C-125 P-1010	LNR-2436-ALT	AT-C-121 P-1006 (6 1/2" Wide)
LNR-2432	P-1017	LNR-2435	AT-C-120 P-1005		

"YOUR HEADQUARTERS FOR ASPHALT PLANT REPLACEMENT PARTS"

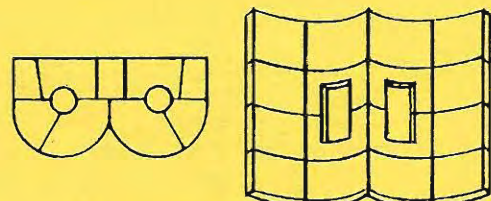

MIXER LINERS

AVAILABLE REPLACEMENT PARTS FOR CMI (SIMPLICITY) PLANTS



C.P.I. PART No.	REPLACEMENT FOR O.E.M. PART No.	C.P.I. PART No.	REPLACEMENT FOR O.E.M. PART No.	C.P.I. PART No.	REPLACEMENT FOR O.E.M. PART No.
LNR-2661	MX-38	LNR-2711-R	MX-116-R	LNR-2746-R1	MX-107-R
LNR-2662	MX-104	LNR-2711-L	MX-116-L	LNR-2746-R2	MX-107-R
LNR-2663	MX-102	LNR-2737	314-00532-0000 5-MX-35-L	LNR-2747-L1	MX-106
LNR-2664	MX-103	LNR-2738	314-00530-0000 5-MX-35-L	LNR-2747-R1	MX-106
LNR-2665	MX-101	LNR-2739	314-00533-0000 5-MX-35-R	LNR-2748	314-00535-0000 MX-134
LNR-2666	314-00520-0000 MX-130	LNR-2740	314-00531-0000 5-MX-35-R	LNR-2749	314-00510-0000 MX-109
LNR-2667	MX-129	LNR-2741	314-00534-0000 MX-133	LNR-2750	236-00021-0000 5-MX-50
LNR-2668	MX-117	LNR-2742	314-00524-0000 5-MX-60	LNR-2750-L2	236-00019-0000 5-MX-6L
LNR-2686-R	314-00502-0000 MX-35-R	LNR-2743	314-00523-0000 5-MX-38A	LNR-2750-R2	236-00020-0000 5-MX-6R
LNR-2686-L	314-00501-0000 MX-35-L	LNR-2746-L1	MX-107-L	LNR-2751	314-00509-0000 MX-108
LNR-2687	MX-6-L, MX-6-R MX-50	LNR-2746-L2	MX-107-L	LNR-2752	MX-110
LNR-2709	314-00512-0000 MX-114			LNR-2753	314-00519-0000 MX-127
LNR-2710	314-00513-0000 MX-115				

LINER BOLTS - Available

AVAILABLE REPLACEMENT PARTS FOR LITTLEFORD PLANTS

C.P.I. PART No.	REPLACEMENT FOR O.E.M. PART No.	C.P.I. PART No.	REPLACEMENT FOR O.E.M. PART No.	C.P.I. PART No.	REPLACEMENT FOR O.E.M. PART No.
LNR-2483	Segmental Liner	LNR-2486-R	End Liner	LNR-2501	3731729
LNR-2484-R	3732007	LNR-2486-L	End Liner	LNR-2502-R	3721727
LNR-2484-L	3732006	LNR-2487	Gate Liner	LNR-2502-L	3721726
LNR-2485	Center Wear Plate	LNR-2488	Skin Plate	LNR-2503	3721724
		LNR-2500	3721725	LNR-2504	3731728

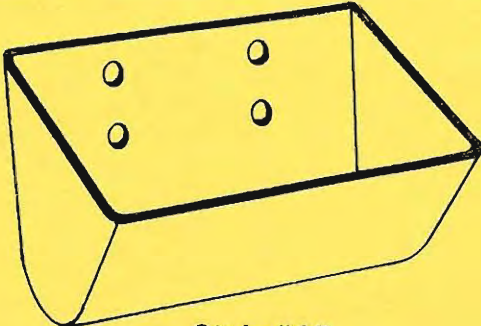
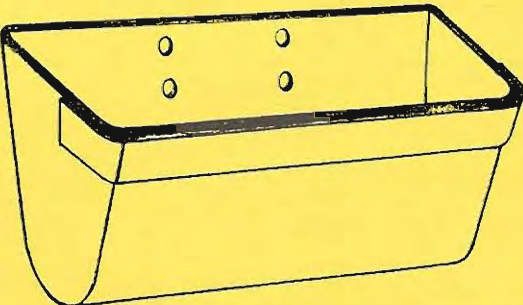
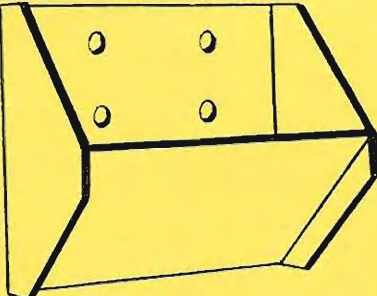
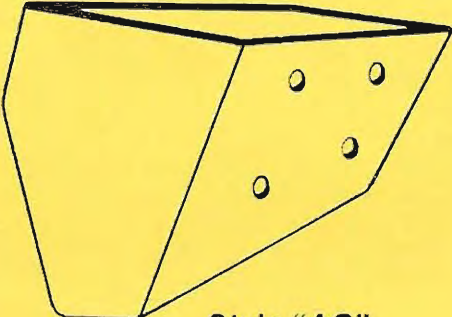
STEEL ELEVATOR BUCKETS

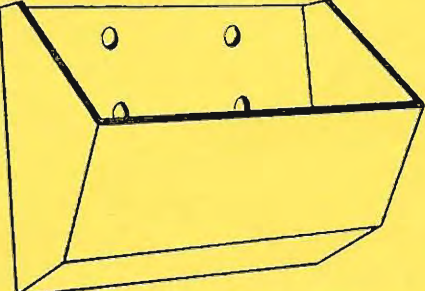
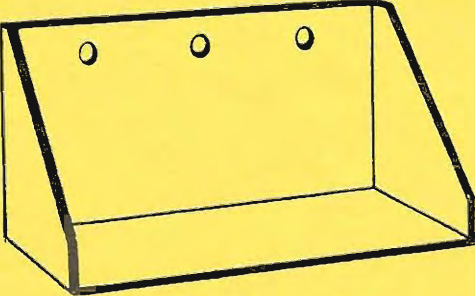
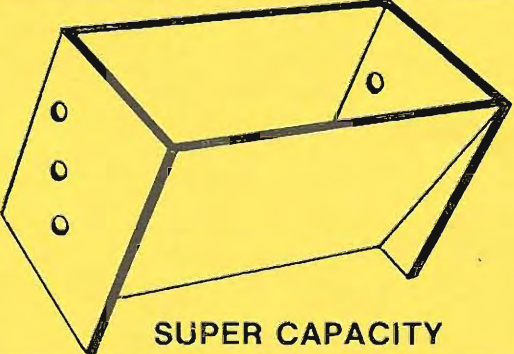
 <p>Style "A"</p>	 <p>Style "AA" (with reinforcing strip)</p>
 <p>CONTINUOUS type (style #2)</p>	 <p>Style "AC"</p>
 <p>SALEM</p>	 <p>CONTINUOUS type (style #4)</p>
 <p>Style "C" (square heel)</p>	 <p>SUPER CAPACITY</p>



STEEL FABRICATED ELEVATOR BUCKETS

All Styles and Sizes

- Style "A" Plain Bucket
- Style "AA" Bucket w/Reinforced Lip
- Style "AARB" Bucket w/Reinforced Lip and Back (Not Shown)

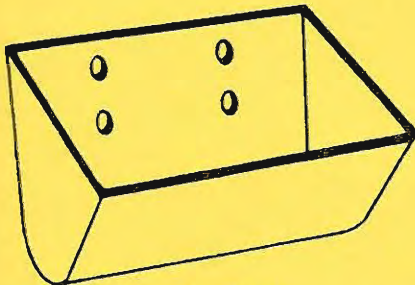

Style "A"

To Obtain Quote:

- 1 Style Bucket _____
- 2 Size Bucket _____ (Thickness _____)
- 3 'K' Attachment _____ (Chain Size _____)
- 4 With ___ Or Without ___ Drain Holes

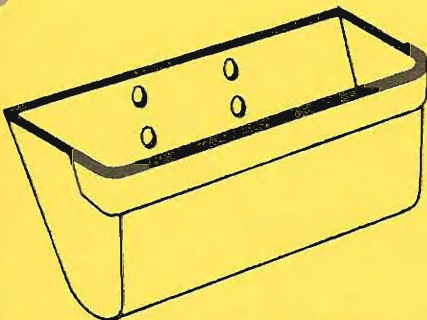

Style "AA" (with reinforcing strip)

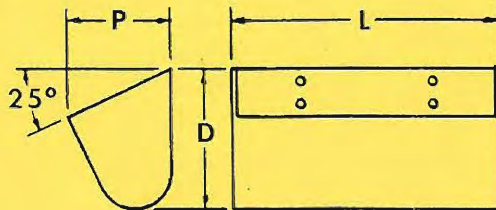

Size of Buckets			Cap. Cu. Ft.
L	P	D	
8	5	5 1/4	.065
9	5	5 1/4	.074
10	5	5 1/4	.082
10	6	6 1/4	.119
11	6	6 1/4	.131
12	6	6 1/4	.143
13	6	6 1/4	.155
14	6	6 1/4	.167
16	6	6 1/4	.191
18	6	6 1/4	.216
12	7	7 1/4	.201
13	7	7 1/4	.219
14	7	7 1/4	.237
16	7	7 1/4	.272
18	7	7 1/4	.307
20	7	7 1/4	.342
12	8	8 1/4	.235
14	8	8 1/4	.279
16	8	8 1/4	.323
18	8	8 1/4	.367
20	8	8 1/4	.411
22	8	8 1/4	.455
24	8	8 1/4	.499
16	9	9 1/4	.372
18	9	9 1/4	.405
20	9	9 1/4	.438
24	9	9 1/4	.504
18	10	10 1/2	.443
20	10	10 1/2	.491
22	10	10 1/2	.541
24	10	10 1/2	.590
30	10	10 1/2	.740

These buckets are three piece, all welded construction. Ends not tapered. Projection is parallel to back. Buckets with reinforced back and/or front can be furnished at slight extra cost. Sizes and gauges not listed can be furnished. Prices on application.

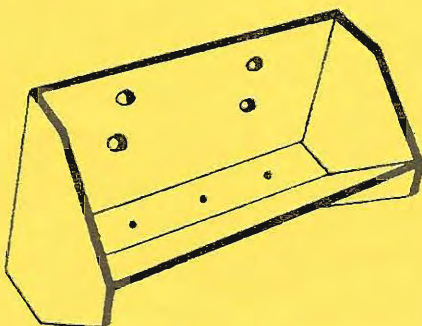

Continuous Type



Style "AC"

ELEVATOR CHAINS

CAST CHAINS / STEEL CHAINS

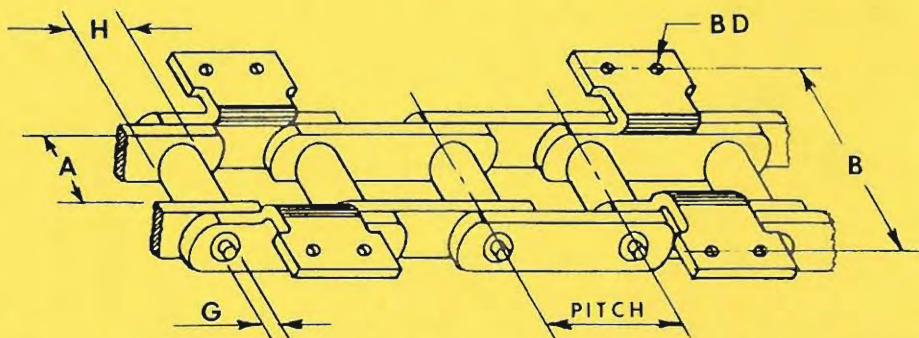

Chains with K-2 or K-24 Attachments

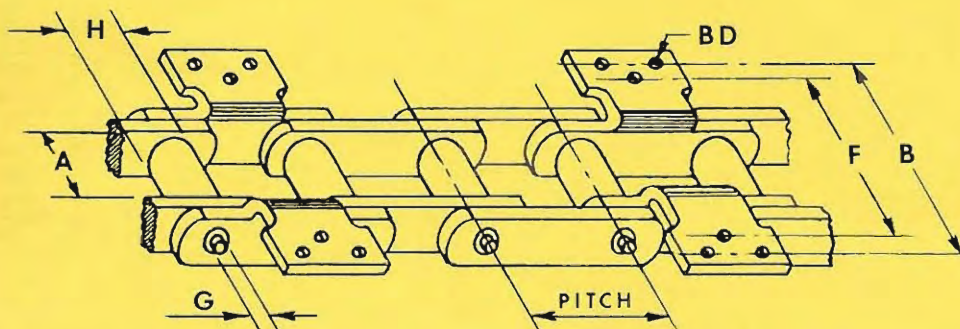
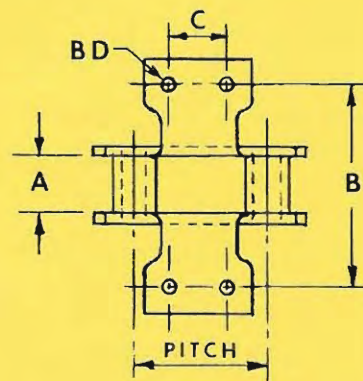

Chains with K-3 or K-35 Attachments

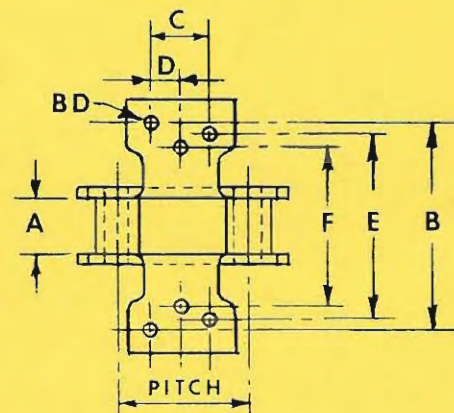

CAST CHAIN NUMBER	STEEL CHAIN NUMBER	PITCH	MAXIMUM ALLOWABLE SPROCKET FACE (A)	DIAMETER OF PIN (G)	DIAMETER OF BARREL (H)	ATTACHMENT DATA						
						ATTACHMENT NO.	BD BOLT DIAMETER	B	C	D	E	F
DIMENSIONS IN INCHES												
CC102B		4.000	2	5/8	1	CC102B-K2	3/8	5 5/16	1 3/4			
	SG102B	4.000	2 1/8	5/8	1	SC102B-K2	3/8	5 5/16	1 3/4			
CC102 1/2		4.040	2	3/4	1 3/8	CC102 1/2-K2	3/8/1/2	5 5/16	1 3/4			
	SC102 1/2	4.040	2 1/4	3/4	1 3/8	SC102 1/2-K2	3/8/1/2	5 5/16	1 3/4			
CC110		6.000	1 15/16	5/8	1 1/4	CC110-K2	3/8	5 5/16	1 3/4			
	SC110	6.000	2 1/8	5/8	1 1/4	SC110-K2	3/8	5 5/16	1 3/4			
CC111		4.760	2 3/8	3/4	1 7/16	CC111-K2	1/2	6 1/4	2 5/16			
	SC111	4.760	2 5/8	3/4	1 7/16	SC111-K2	1/2	6 1/4	2 5/16			
CC131		3.075	1 1/8	5/8	1 1/4	CC131-K2	1/2	4 1/8	1 1/2			
	SC131	3.075	1 5/16	5/8	1 1/4	SC131-K2	1/2	4 1/8	1 1/2			
CC132		6.050	3 1/8	1	1 3/4	CC132-K2	1/2	7 1/2	2 3/4			
CC188		2.609	15/16	1/2	7/8	CC188-K2	5/16	4 3/16	1 1/8			
	SC188	2.609	1 7/16	1/2	7/8	SC188-K2	5/16	4 3/16	1 1/8			
	SC856	6.000	3	1	1 3/4	SC856-K2	1/2	6 5/16	2 1/4			
	SC856	6.000	3	1	1 3/4	SC856-K14	5/8	7 1/4	2 1/2			
	SC856	6.000	3	1	1 3/4	SC856-K1	1/2	12 1/16	2 3/4	1 3/8	10 15/16	6 9/16
	SC856	6.000	3	1	1 3/4	SC856-K35	5/8	11 3/4	2 1/2	1 1/4	11 3/4	7 1/4

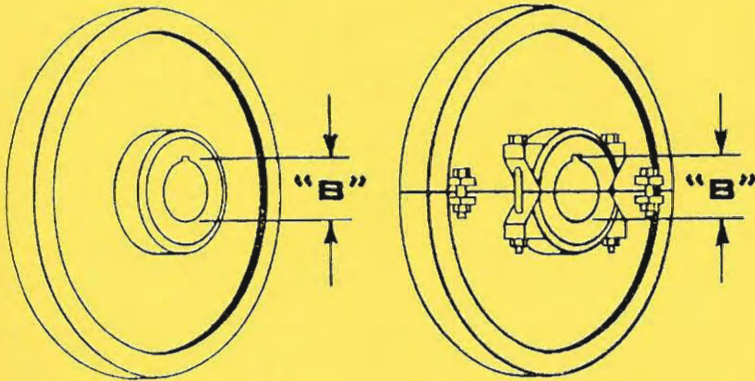

Solid Type

Split Type

TRACTION WHEELS
COMPLETE W/HUB
(Including Standard Keyway
And Set Screws)

Information Required
To Quote.....

Solid Type Split Type
Wheel Diameter _____
Chain Size _____
Bore Diameter "B" _____
(Shaft Diameter)

TRACTION WHEELS

C.P.I. PART NO.	PART DESCRIPTION	STEEL OR CAST CHAIN No.
HEP-5500	24" Dia. Split Traction Wheel	102-B
HEP-5501	24" Dia. Split Traction Wheel	102½
HEP-5502	24" Dia. Split Traction Wheel	110
HEP-5503	24" Dia. Split Traction Wheel	111
HEP-5504	30" Dia. Split Traction Wheel	111
HEP-5505	21½" Dia. Split Traction Wheel	856
HEP-5506	26" Dia. Split Traction Wheel	856
HEP-5507	30" Dia. Split Traction Wheel	856

CONTACT C.P.I. FOR DIAMETERS AND CHAIN SIZES NOT SHOWN.



ORDER BY PHONE

TOLL FREE
1-800-222-1141

Ohio 1-800-338-5608

FAX 216-524-5682

Telephone 216-524-7100

TRACTION WHEELS

Segmental - Rim

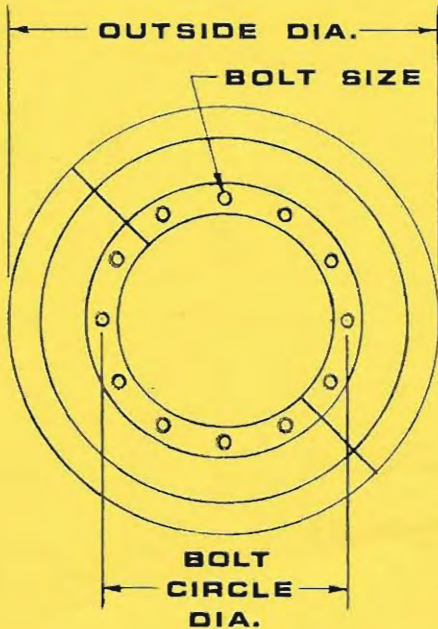

(2) SEGMENTS

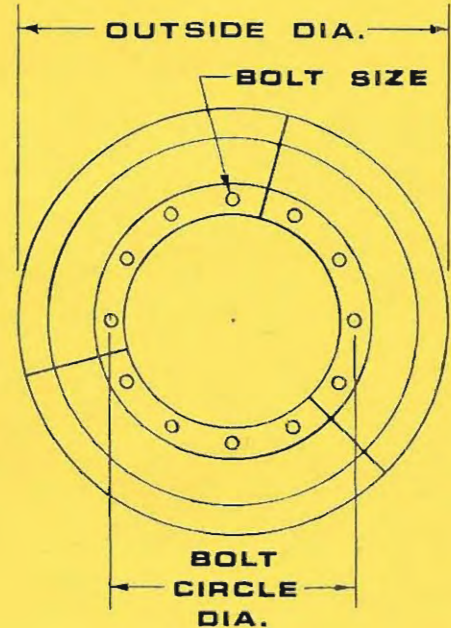
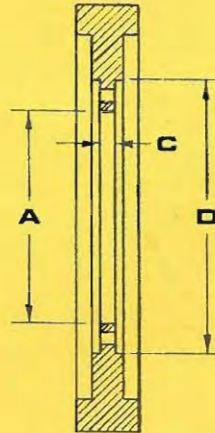

(3) SEGMENTS

TRACTION WHEEL PART NO.	HUB BODY NO.	BOLT CIRCLE DIAMETER	BOLT SIZE	A	C	D	E
ETW-1010	CPI-1010	10	1/2	8-1/2	5/8	12-1/4	11-3/4
ETW-1212	CPI-1212	12	5/8	10-1/2	3/4	14-1/4	13-3/4
ETW-1616	CPI-1616	16	3/4	14-1/2	3/4	18-1/4	17-3/4
ETW-2020	CPI-2020	20	3/4	18-1/2	7/8	22-1/4	21-3/4
ETW-2525	CPI-2525	25	1	23	1	28-1/4	27-3/4

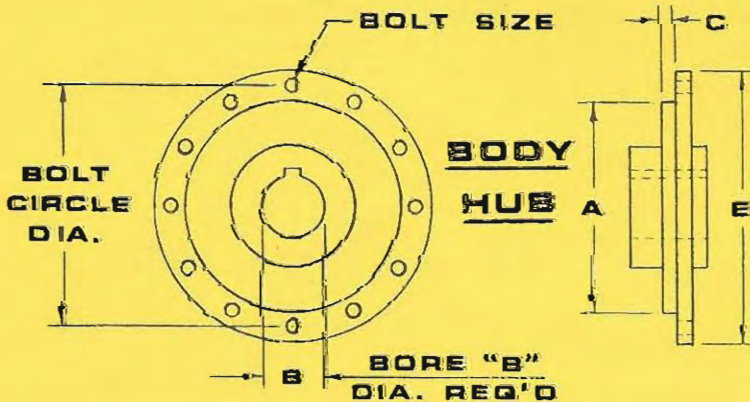

TRACTION WHEELS

To Order, Specify

Outside Dia. _____

Chain Size _____

(2) Segments _____

or

(3) Segments _____

Bore Diameter "B" _____

(Shaft Diameter)

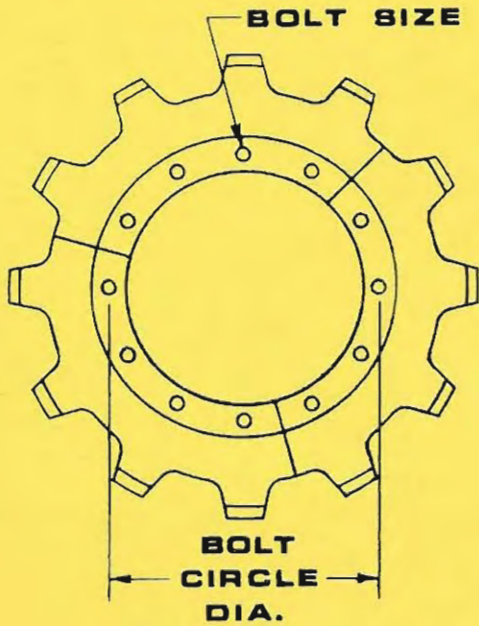

(3) SEGMENTS

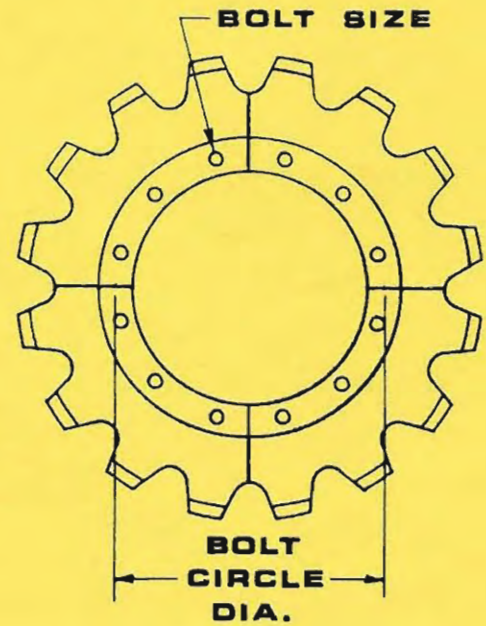
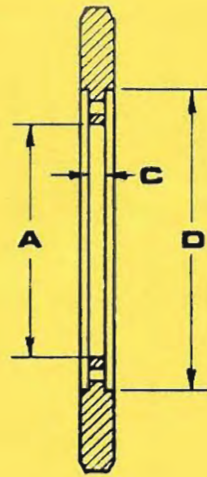

(4) SEGMENTS

SPROCKET PART NO.	HUB BODY NO.	BOLT CIRCLE DIAMETER	BOLT SIZE	A	C	D	E
TRP-1010	CPI-1010	10	1/2	8-1/2	5/8	12-1/4	11-3/4
TRP-1212	CPI-1212	12	5/8	10-1/2	3/4	14-1/4	13-3/4
TRP-1616	CPI-1616	16	3/4	14-1/2	3/4	18-1/4	17-3/4
TRP-2020	CPI-2020	20	3/4	18-1/2	7/8	22-1/4	21-3/4
TRP-2525	CPI-2525	25	1	23	1	28-1/4	27-3/4

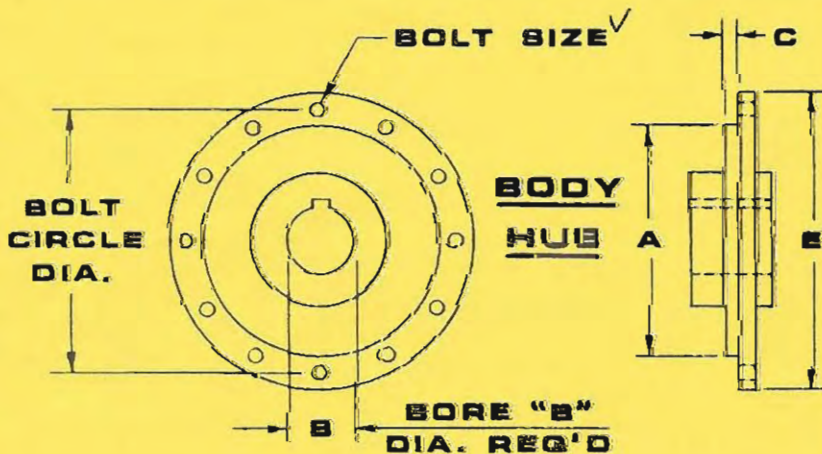

SPROCKETS
To Order, Specify

No. Of Teeth _____

Chain Size _____

(3) Segments _____
or
(4) Segments _____

Bore Diameter "B" _____
(Shaft Diameter)

C ONSTRUCTION P ARTS I NC.®



ORDER
BY PHONE

TOLL FREE
1-800-222-1141

Ohio 1-800-338-5608

FAX 216-524-5682

Telephone 216-524-7100

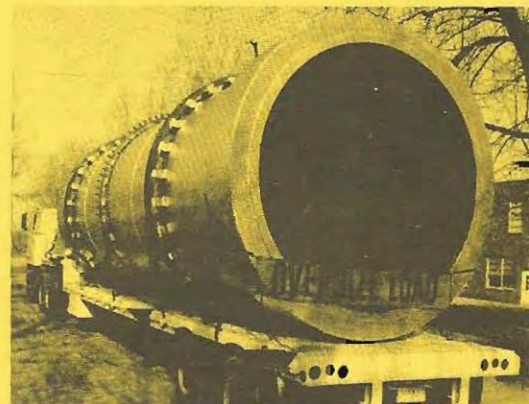

COMPLETE DRYER SHELL REPLACEMENT

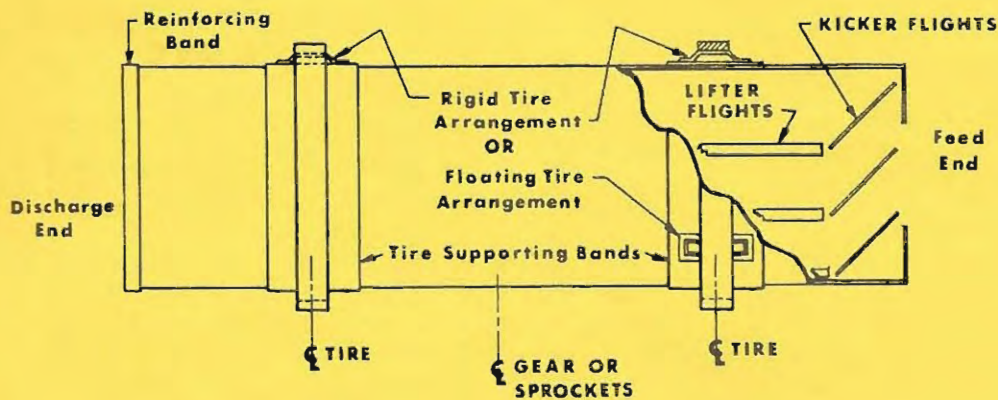

Prices Upon Request

- Complete Dryer Shell
- Dryer Shell Only
- Dryer Flights
- Dryer Tires

Replacement for.....
BARBER-GREENE, CEDARAPIDS, H & B
MADSEN, STANSTEEL, M^CCARTER and
many other ASPHALT PLANT makes.

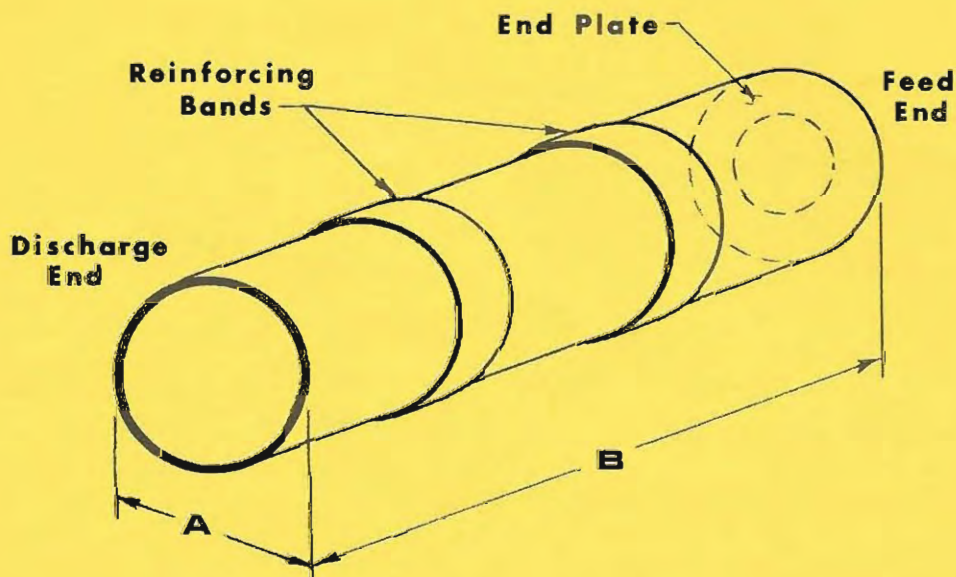

To Obtain Quote
(Need following dimensions)

A _____ Diameter

B _____ Length

"YOUR HEADQUARTERS FOR ASPHALT PLANT REPLACEMENT PARTS"

ORDER BY PHONE **TOLL FREE**
1-800-222-1141
Ohio 1-800-338-5608

FAX 216-524-5682

Telephone 216-524-7100

DRYER TIRES

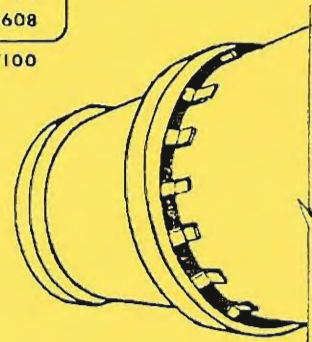
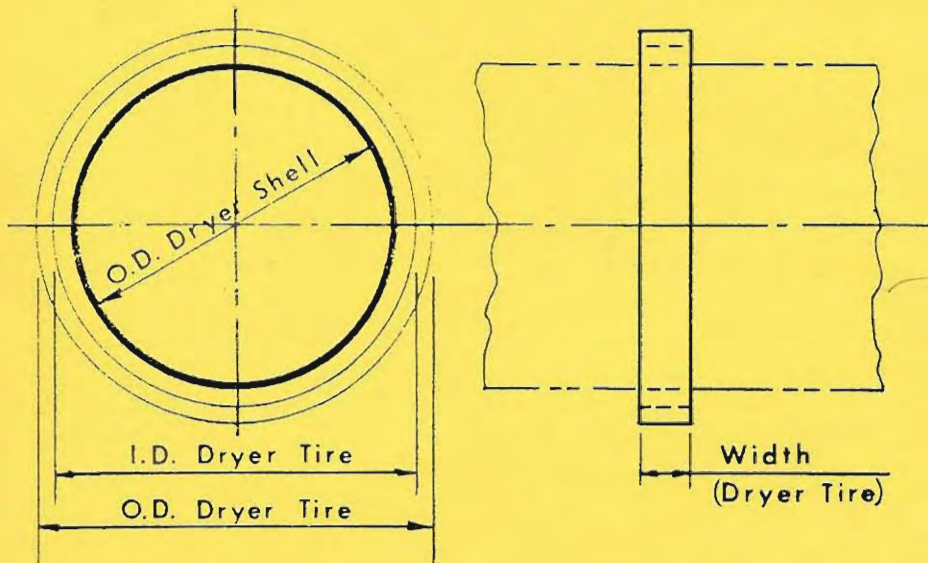

To Obtain Quote.....
(Need following information)

- _____ O.D. Dryer Tire
- _____ I.D. Dryer Tire
- _____ Width (Dryer Tire)

DRYER TRUNNIONS

Dimensions needed to obtain Quote.

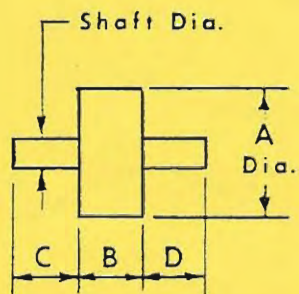

PLAIN TRUNNION
(For Gear Drive)

- A _____ Trunnion Diameter
- B _____ Trunnion Face (Width)
- C _____ Shaft Projection
- D _____ Shaft Projection
- E _____ Trunnion Face
- _____ Shaft Dia. w/ Keyway
- _____ Shaft Dia. w/o Keyway

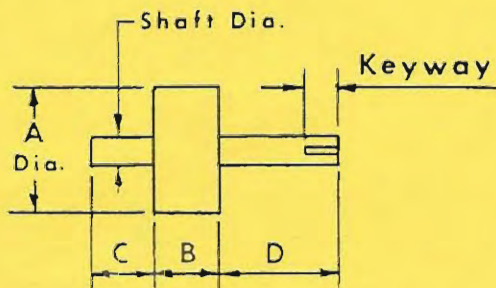

PLAIN TRUNNION
(For Trunnion Drive)

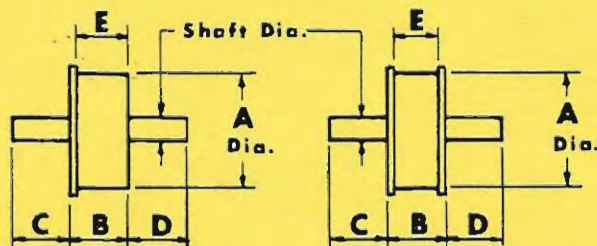

SINGLE FLANGE TRUNNION **DOUBLE FLANGE TRUNNION**



ORDER
BY PHONE

TOLL FREE
1-800-222-1141

FAX: 216-524-5682

Ohio 1-800-338-5608

216-524-7100

DRYER PARTS

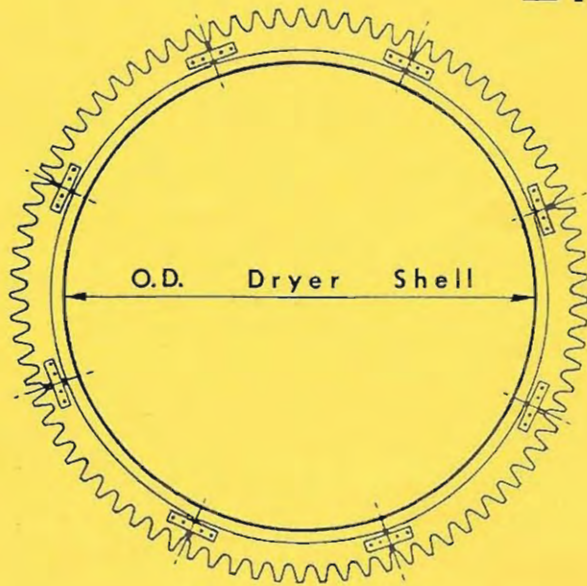

SEGMENTAL SPROCKET

(w/Installation Tie Bars)

Information Required To Quote

Total Number Of Teeth _____

Number Of Segments _____

Chain Size _____

Outside Diameter _____
(Dryer Shell)

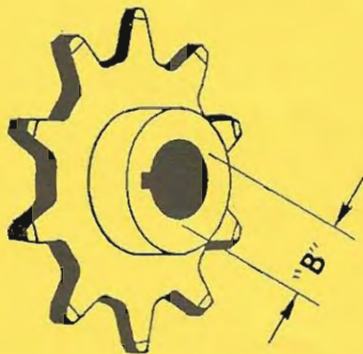

DRIVE SPROCKET COMPLETE W/HUB

(Including Standard Keyway
And Set Screws)

Information Required To Quote

Number Of Teeth _____

Chain Size _____

Bore Diameter "B" _____
(Shaft Diameter)

C.P.I. PART NO.	PITCH IN INCHES
DCH-2000	2.000
DCH-2500	2.500
DCH-2563	2.563
DCH-2609	2.609
DCH-3000	3.000
DCH-3067	3.067
DCH-3075	3.075
DCH-3075-A	3.075
DCH-3075-B	3.075
DCH-3500	3.500

DRIVE CHAIN

(Offset Type Shown)

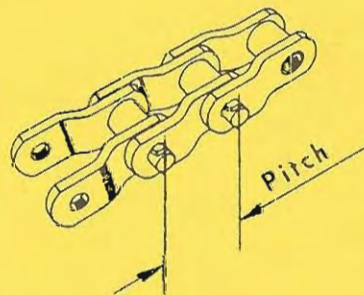

C.P.I. PART NO.	PITCH IN INCHES
DCH-4063	4.063
DCH-4063-A	4.063
DCH-4073	4.073
DCH-4090	4.090
DCH-4090-A	4.090
DCH-4500	4.500
DCH-5000	5.000
DCH-5000-A	5.000
DCH-5500	5.500
DCH-6000	6.000



ORDER
BY PHONE

TOLL FREE

1-800-222-1141

FAX: 216-524-5682

Ohio 1-800-338-5608

216-524-7100

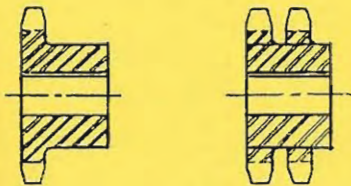

Type "B"
Hub - One Side

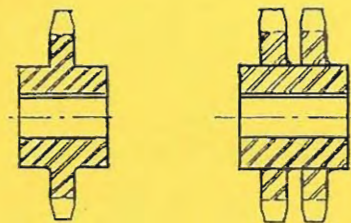

Type "C"
Hub - Both Sides

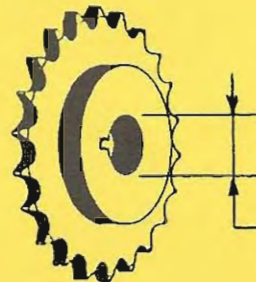

DRIVE CHAIN SPROCKETS

(Including Standard Keyway
And Set Screws)

Information Required To Quote

- Number Of Teeth _____
- Chain Size _____
- Single Strand Chain _____
- Double Strand Chain _____
- Bore Diameter (Shaft Diameter) _____
- Type "B" _____ Type "C" _____

ROLLER CHAIN

C.P.I. PART No.	PITCH	ROLLER	
		DIA. A	WIDTH B
ROLLER CHAIN - Single Strand			
DCH-60	3/4	15/32	1/2
DCH-80	1	5/8	5/8
DCH-100	1 1/4	3/4	3/4
DCH-120	1 1/2	7/8	1
ROLLER CHAIN - Double Strand			
DCH-120-2	1 1/2	7/8	1
DCH-140-2	1 3/4	1	1
DCH-200-2	2 1/2	1 9/16	1 1/2
DCH-240-2	3	1 7/8	1 7/8

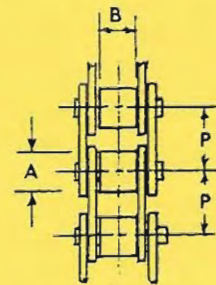

Single Strand

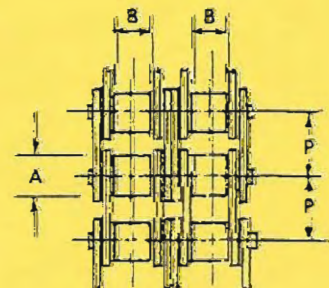

Double Strand



ORDER
BY PHONE

TOLL FREE
1-800-222-1141

FAX: 216-524-5682

Ohio 1-800-338-5608

216-524-7100

IGNITION CONES

Replacement For.....
GENCO IGNITION CONES

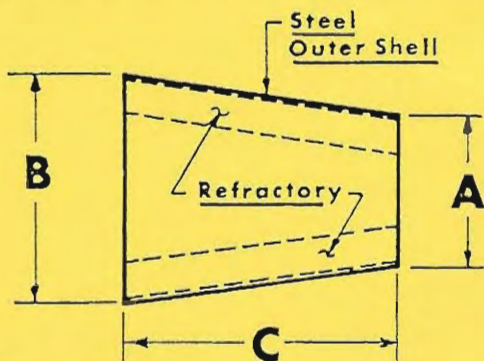

C.P.I. PART NO.	GENCO BURNER SIZE	PORT SIZE
DRP-4146	FP-40,51,69	K-20
DRP-4147	FP-86	K-21
DRP-4148	FP-103,129	K-22
DRP-4149	FP-162	K-23
DRP-4150	FP-202	K-24
DRP-4151	FP-248	K-25
DRP-4152	#301/#401/#501/#601	
DRP-4153	#751/#1001/#1251	

C.P.I.No.	A	B	C
DRP- 4146	17 $\frac{1}{2}$	26	37
DRP- 4147	20 $\frac{1}{2}$	30	37
DRP- 4148	23	33	37
DRP- 4149	25 $\frac{1}{4}$	36	37
DRP- 4150	25 $\frac{1}{4}$	39	37
DRP- 4151	29 $\frac{1}{4}$	43	37
DRP- 4152	20 $\frac{1}{2}$	34	37
DRP- 4153	25 $\frac{1}{4}$	39	37

CONSTRUCTION OF IGNITION CONE

Outer shell to be 3/16" Thick Steel.
Lining will be of "High Temperature"
Super Duty Castable Refractory anchored
to shell with stainless steel V-anchor

Replacement For.....
HAUCK IGNITION CONES

CUSTOMIZED-IGNITION CONES

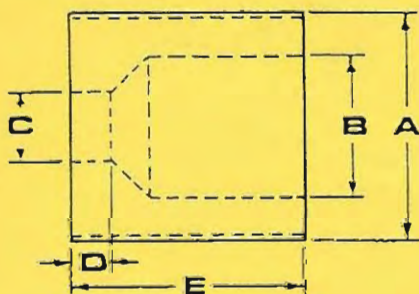

STRAIGHT CONE

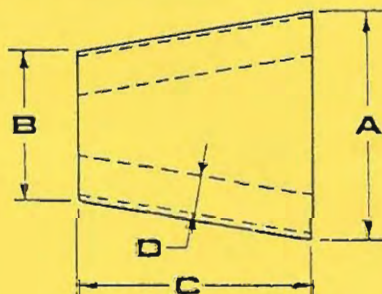

TAPERED CONE

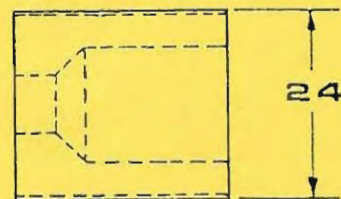

STRAIGHT CONE

Hauck No. JLP-4250

DRP-4554

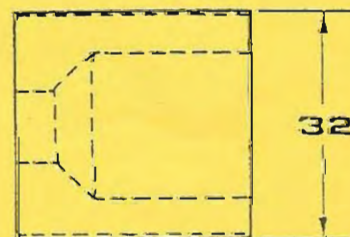

STRAIGHT CONE

Hauck No. J-375-5000

DRP-4443

DIMENSIONS NEEDED FROM YOU TO OBTAIN QUOTE

- A — OUTSIDE DIAMETER
- B — INSIDE DIAMETER
- C — INSIDE DIAMETER
- D — DEPTH
- E — OVERALL LENGTH

- A — MAX. DIAMETER
- B — MIN. DIAMETER
- C — OVERALL LENGTH
- D — THICKNESS (Refractory)



These bearings are used for supporting auger shafts and for other low-speed applications where lubricated bearings are impractical. Made of **NI-CHROME** . . . , they will give long service when operating in dust, sand, concrete slurry, or other abrasive environments. Use with coupling pins shown at bottom of page.

CPI-9507 U

CPI-9508 U

CPI-9509 U

CPI-9507 L

CPI-9508 L

CPI-9509 L

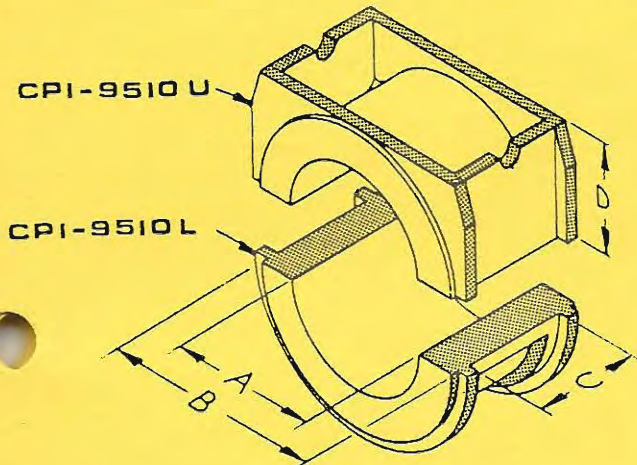

CPI-9511
CPI-9512
CPI-9513

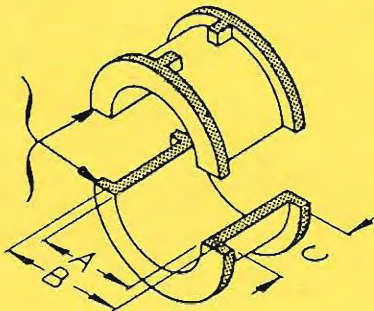

Bearing Hanger Style	PART Number	Upper or Lower	DIMENSIONS				Weight (Lb.)
			A	B	C	D	
216 & 316	CPI-9507 U	upper	$1\frac{17}{32}$		$1\frac{1}{2}$	$1\frac{5}{8}$	1
	CPI-9507 L	lower	$1\frac{17}{32}$	$2\frac{1}{4}$	$1\frac{1}{2}$		$\frac{1}{2}$
	CPI-9508 U	upper	2		$1\frac{1}{2}$	$1\frac{5}{8}$	$1\frac{1}{2}$
	CPI-9508 L	lower	2	$3\frac{1}{4}$	$1\frac{1}{2}$		$1\frac{1}{2}$
	CPI-9509 U	upper	$2\frac{7}{16}$		$1\frac{5}{8}$	$2\frac{1}{16}$	4
	CPI-9509 L	lower	$2\frac{7}{16}$	4	$1\frac{5}{8}$		$3\frac{1}{4}$
	CPI-9510 U	upper	3		$2\frac{1}{8}$	$2\frac{9}{16}$	$3\frac{1}{2}$
	CPI-9510 L	lower	3	$4\frac{1}{2}$			3
220 & 226	CPI-9511	upper & lower	$1\frac{1}{2}$	$2\frac{1}{8}$	$1\frac{5}{8}$		$\frac{1}{2}$ ea.
	CPI-9512	upper & lower	2	$2\frac{3}{4}$	$1\frac{1}{2}$		1 ea.
326	CPI-9513	upper & lower	3	4	$2\frac{3}{8}$		$2\frac{1}{2}$ ea.

COUPLING (GUDGEON) PINS

PART Number	Weight (Lb.)	DIMENSIONS					Bolt Hole Size
		A	B	C	D	E	
CPI-9514	$5\frac{1}{2}$	12	$1\frac{1}{8}$	3	$1\frac{17}{32}$	$3\frac{3}{4}$	$\frac{1}{2}$
CPI-9515	$7\frac{3}{4}$	12	$1\frac{1}{8}$	3	2	$3\frac{3}{4}$	$\frac{5}{8}$
CPI-9516	$13\frac{1}{2}$	$12\frac{3}{4}$	$\frac{15}{16}$	3	$2\frac{7}{16}$	$4\frac{7}{8}$	$\frac{5}{8}$
CPI-9517	$23\frac{1}{2}$	13	1	3	3	5	$\frac{3}{4}$

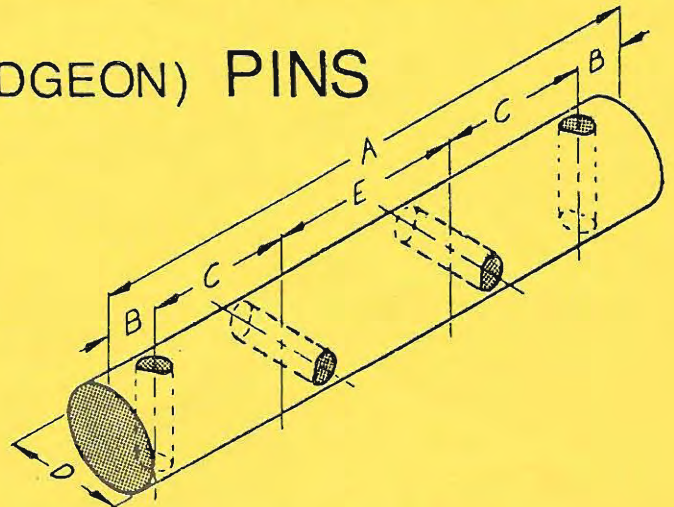



**"The Super Plate
For SUPER Wear"**

The **"ULTIMATE"** For
Chute Liners And High
Abrasive Areas.

STANDARD BARS AND PLATES

(With Countersunk Holes For Bolting Or Plug Welding)

<u>C.P.I. NO.</u>	<u>DESCRIPTION</u>	<u>C.P.I. NO.</u>	<u>DESCRIPTION</u>
STR-111	1 1/4" x 11" x 1/4"	PLT-209	9" x 20 3/4" x 3/4"
STR-112	1 1/4" x 12" x 3/8"	PLT-621-6	6" x 21" x 3/4"
STR-118-3	1" x 18" x 3/8"	PLT-812	8" x 12" x 1/2"
STR-216	2" x 16" x 3/4"	PLT-820	8" x 19 7/8" x 1/2"
STR-218	2" x 18" x 1/2"	PLT-918-3	9" x 18" x 3/8"
STR-316	3" x 16" x 1/2"	PLT-918-4	9" x 18" x 1/2"
STR-318-3	3" x 18" x 3/8"	PLT-1218-3	12" x 18" x 3/8"
STR-318-4	3" x 18" x 1/2"	PLT-1218-4	12" x 18" x 1/2"
STR-416-3	4 3/4" x 16 3/4" x 3/8"	LNR-2562	3 1/4" x 12 7/8" x 3/4"
STR-416-4	4 3/4" x 16 3/4" x 1/2"	LNR-2564	1 3/4" x 23 1/4" x 3/4"
STR-618-3	6" x 18" x 3/8"		
STR-618-4	6" x 18" x 1/2"		

CHECK WITH C.P.I. FOR
ADDITIONAL SIZES

AVAILABLE - SILO PLATES

CUSTOMIZED BARS and PLATES

(To Suit Your Application)

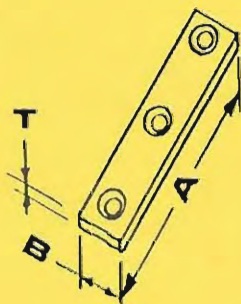

BARS

SPECIFY:

- A Length
- B Width
- T Thickness

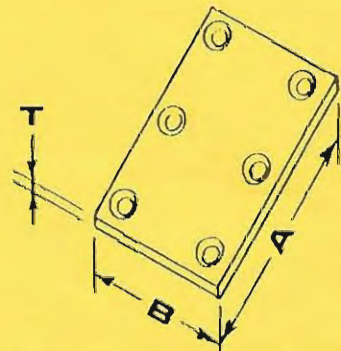
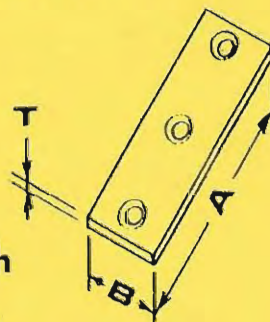

PLATES

C O N S T R U C T I O N P A R T S I N C. ®

AVAILABLE REPLACEMENT PARTS
FOR
STANDARD-HAVEN SILOS

ORDER BY PHONE **TOLL FREE**
1-800-222-1141
FAX: 216-524-5682

Ohio 1-800-338-5608

216-524-7100

**SAVE UP TO 50%
WITH NI-CHROME "600"**

CONVEYOR BOTTOM PLATES

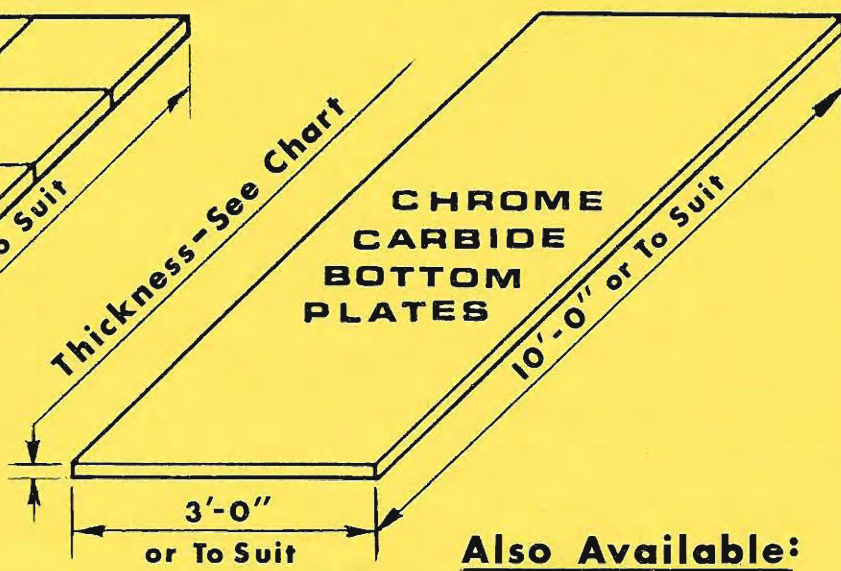
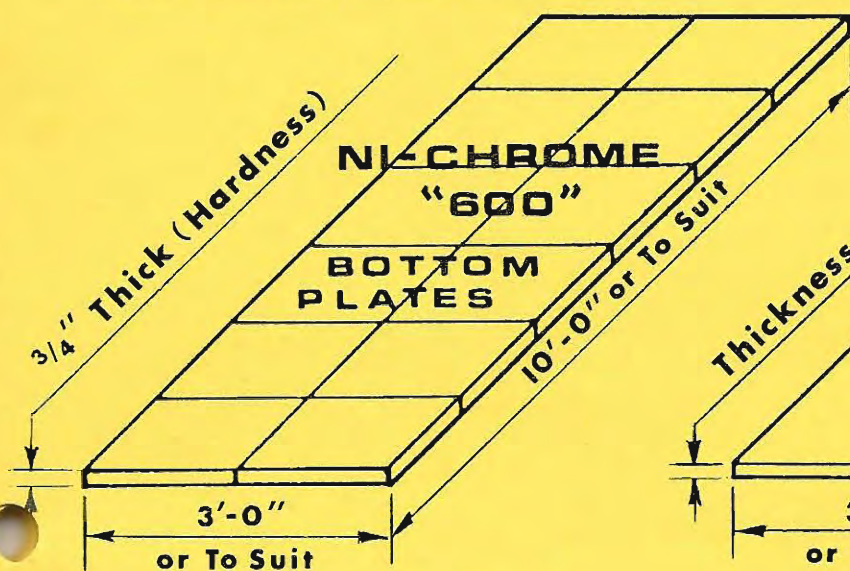

NI-CHROME "600" (Segmental Type)

Each Segment Has (4) Corner Holes For Plug Welding In Place. (12) Segments Make-Up 3' x 10' Area

Also Available:

CHROME CARBIDE PLATES	
1/4" Plate With	1/8" Overlay (Hardness)
1/4" Plate With	1/4" Overlay (Hardness)
5/16" Plate With	5/16" Overlay (Hardness)
3/8" Plate With	3/8" Overlay (Hardness)

C.P.I.

PART NO.

PART DESCRIPTION

REPLACEMENT FOR

O.E.M. PART NO.

ASP-1020	Bottom Plates (12 Pcs. Make-Up)	622-0077
ASP-1021	Bottom Plates (16 Pcs. Make-Up)	624-0644
ASP-1022	Bottom Plates (6 Pcs. Make-Up)	622-0113
ASP-1023	Bottom Plates (4 Pcs. Make-Up)	624-0213
ASP-1024	Bottom Plates (4 Pcs. Make-Up)	624-0188
ASP-1025	Bottom Plates (12 Pcs. Make-Up)	624-0513
ASP-1026	Bottom Plates (2 Pcs. Make-Up)	622-0145
ASP-1027	Bottom Plates	622-0831
ASP-1028	Bottom Plates	642-0413

"YOUR HEADQUARTERS FOR ASPHALT PLANT REPLACEMENT PARTS"

**AVAILABLE REPLACEMENT PARTS
 FOR
 STANDARD-HAVEN SILOS**

C.P.I. PART No. REPLACEMENT FOR O.E.M. PART No.

ASP-1000 830-0051

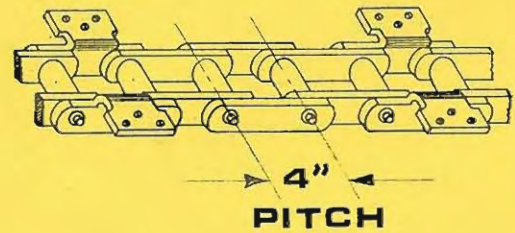

ASP-1001 830-0055

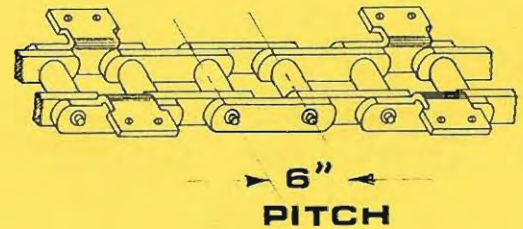

SILO SPROCKETS

C.P.I. PART No.	PART DESCRIPTION	REPLACEMENT FOR O.E.M. PART No.
TRP-351	11 Tooth Solid Sprocket	830-0291
TRP-352	11 Tooth Split Sprocket	830-0703
TRP-353	15 Tooth Segmental Sprocket	830-0161
TRP-355	13 Tooth Segmental Sprocket	830-0159
TRP-357	13 Tooth Segmental Sprocket	830-0157
TRP-359	15 Tooth Segmental Sprocket	830-0237

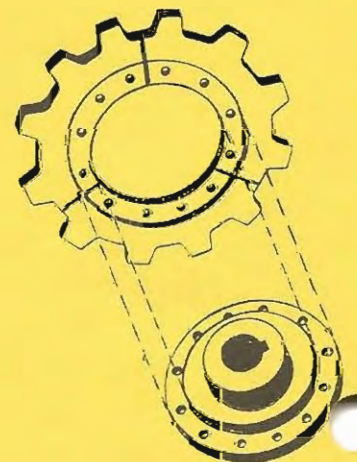

C O N S T R U C T I O N P A R T S I N C. ®



ORDER
BY PHONE

TOLL FREE
1-800-222-1141

FAX: 216-524-5682

Ohio 1-800-338-5608

216-524-7100

AVAILABLE REPLACEMENT PARTS
FOR
ASPHALT STORAGE SILOS

CONVEYOR SLATS

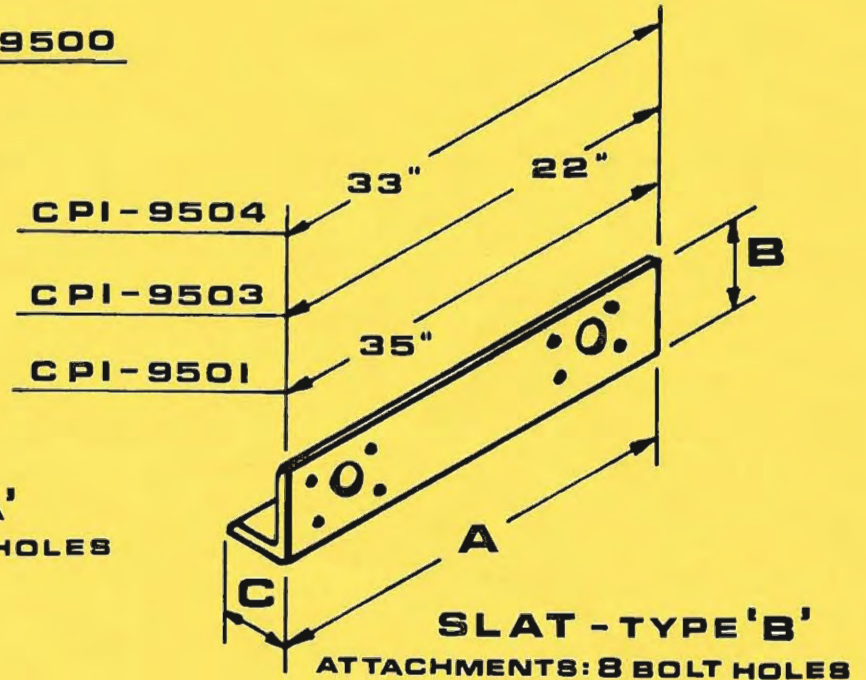
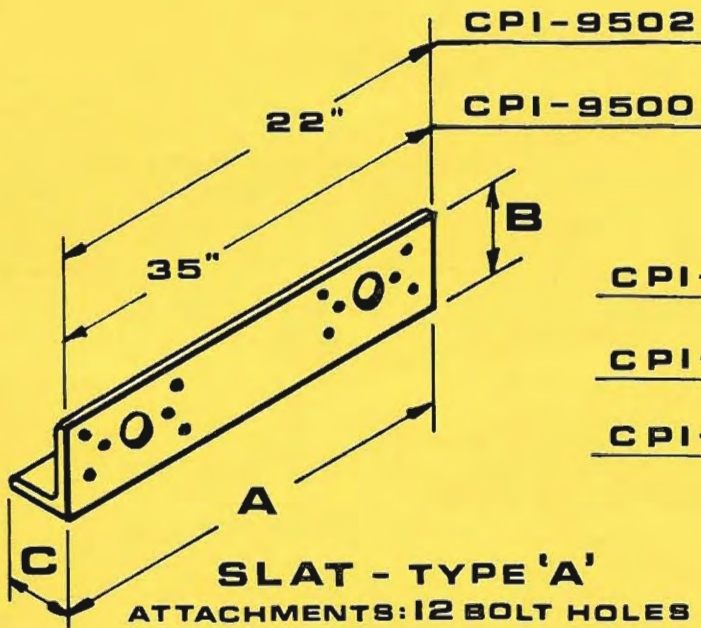

NOTE:

TO QUOTE SLATS, SIZES NOT SHOWN, FOLLOWING
DIMENSIONS ARE REQUIRED: A ___ B ___ C ___

"YOUR HEADQUARTERS FOR ASPHALT PLANT REPLACEMENT PARTS"



ORDER
BY PHONE

TOLL FREE

1-800-222-1141

FAX: 216-524-5682

Ohio 1-800-338-5608

216-524-7100

STEEL BIN GATES

STYLE "DG"

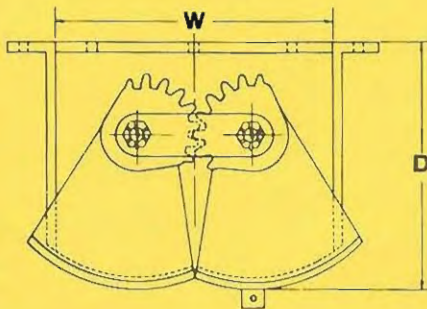

Dual bingates have a hard
surfacing rod on lip edge.

STYLE "S"

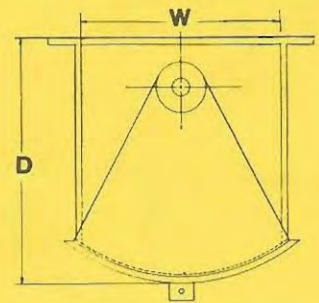

PART NO.	SIZE			Type	PLATE THICKNESS			Approx. Shpg. Wt.
	W	L	D		Body	Clams	Gears	
66-S-316	6"	6"	8"	S	3/16"	3/16"	---	20
88-S-14	8"	8"	10"	S	1/4"	1/4"	---	50
1010-S-14	10"	10"	11"	S	1/4"	1/4"	---	70
1212-S-14	12"	12"	15 1/2"	S	1/4"	1/4"	---	90
1212-D-14	12"	12"	10 1/2"	DG	1/4"	1/4"	3/4"	80
1216-S-14	12"	16"	15 1/2"	S	1/4"	1/4"	---	100
1216-D-14	12"	16"	10 1/2"	DG	1/4"	1/4"	3/4"	90
1414-S-14	14"	14"	17 1/4"	S	1/4"	1/4"	---	115
1414-D-14	14"	14"	11 1/4"	DG	1/4"	1/4"	3/4"	95
1414-D-38	14"	14"	11 1/2"	DG	3/8"	3/8"	3/4"	140
1420-S-14	14"	20"	17 1/4"	S	1/4"	1/4"	---	135
1420-D-38	14"	20"	11 1/2"	DG	3/8"	3/8"	3/4"	160
1515-D-14	15"	15"	12"	DG	1/4"	1/4"	3/4"	105
1515-D-38	15"	15"	12"	DG	3/8"	3/8"	3/4"	150
1520-D-38	15"	20"	12"	DG	3/8"	3/8"	3/4"	170
1524-D-38	15"	24"	12"	DG	3/8"	3/8"	3/4"	180
1616-D-14	16"	16"	12 3/4"	DG	1/4"	1/4"	3/4"	115
1616-D-38	16"	16"	12 3/4"	DG	3/8"	3/8"	3/4"	170
1620-D-38	16"	20"	12 3/4"	DG	3/8"	3/8"	3/4"	190
1624-D-38	16"	24"	12 3/4"	DG	3/8"	3/8"	3/4"	205
1818-D-38	18"	18"	13 1/2"	DG	3/8"	3/8"	1"	200
1822-D-38	18"	22"	13 1/2"	DG	3/8"	3/8"	1"	215
1826-D-38	18"	26"	13 1/2"	DG	3/8"	3/8"	1"	238
2020-D-38	20"	20"	16"	DG	3/8"	3/8"	1"	255
2024-D-38	20"	24"	16"	DG	3/8"	3/8"	1"	280
2028-D-38	20"	28"	16"	DG	3/8"	3/8"	1"	300
2222-D-38	22"	22"	16"	DG	3/8"	3/8"	1"	285
2226-D-38	22"	26"	16"	DG	3/8"	3/8"	1"	310
2424-D-38	24"	24"	17 1/2"	DG	3/8"	3/8"	1"	320
2428-D-38	24"	28"	17 1/2"	DG	3/8"	3/8"	1"	345
2432-D-38	24"	32"	17 1/2"	DG	3/8"	3/8"	1"	370

"YOUR HEADQUARTERS FOR ASPHALT PLANT REPLACEMENT PARTS"



ORDER
BY PHONE

TOLL FREE
1-800-222-1141

Ohio 1-800-338-5608

FAX 216-524-5682

Telephone 216-524-7100

W . . width across ends (inside)
P . . number holes in flanges for W
T . . hole centers
A . . C to C of side hole lines
L . . length (inside)
F . . number holes in flanges for L
K . . hole centers
B . . C to C of end hole lines
H . . size of holes

STYLE "S"

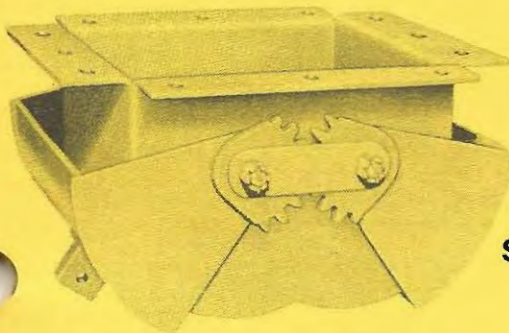
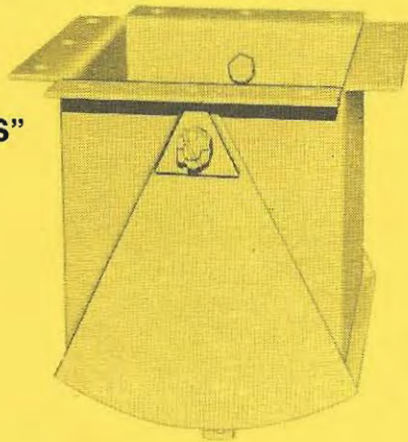

Dual bingates have a hard
surfacing rod on lip edge.

STYLE "DG"

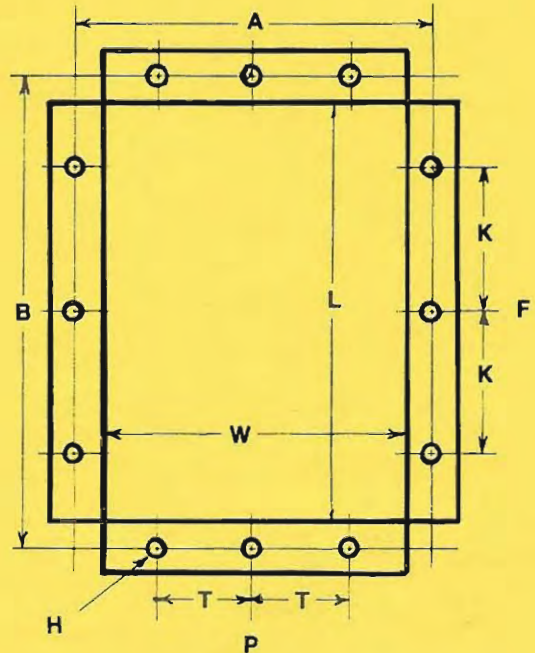

STANDARD PUNCHING FOR BIN GATES

W	P	T	A	L	F	K	B	H
12"	3	5"	14¾"	12"	3	5"	14¾"	9/16"
12"	3	5"	14¾"	16"	4	4⅝"	18¾"	9/16"
14"	3	6"	16¾"	14"	3	6"	16¾"	9/16"
14"	3	6"	16¾"	20"	4	6"	22¾"	9/16"
15"	3	6½"	17¾"	15"	3	6½"	17¾"	9/16"
15"	3	6½"	17¾"	20"	4	6"	22¾"	9/16"
15"	3	6½"	17¾"	24"	5	5½"	26¾"	9/16"
16"	3	7"	19½"	16"	4	4⅝"	19½"	11/16"
16"	3	7"	19½"	20"	4	6"	23½"	11/16"
16"	3	7"	19½"	24"	5	5½"	27½"	11/16"
18"	3	8"	21½"	18"	4	5¼"	21½"	11/16"
18"	3	8"	21½"	22"	5	5"	25½"	11/16"
18"	3	8"	21½"	26"	5	6"	29½"	11/16"
20"	3	9"	23½"	20"	4	6"	23½"	13/16"
20"	3	9"	23½"	24"	5	5½"	27½"	13/16"
20"	3	9"	23½"	28"	5	6½"	31½"	13/16"
22"	5	5"	25½"	22"	5	5"	25½"	13/16"
22"	5	5"	25½"	26"	5	6"	29½"	13/16"
24"	5	5½"	27½"	24"	5	5½"	27½"	13/16"
24"	5	5½"	27½"	28"	5	6½"	31½"	13/16"
24"	5	5½"	27½"	32"	6	6"	35½"	13/16"



"SPECIAL" STEEL BIN GATES

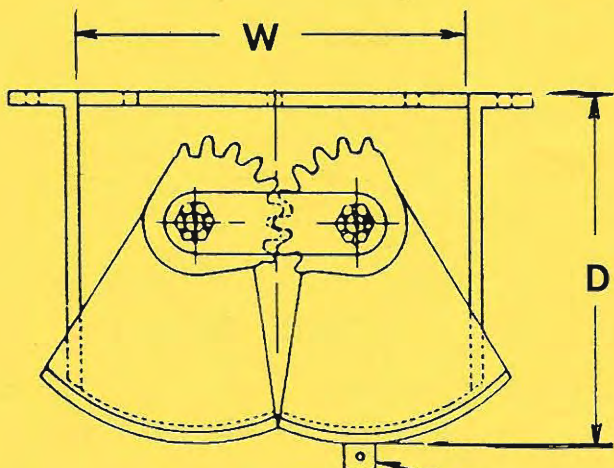

STYLE "DG"

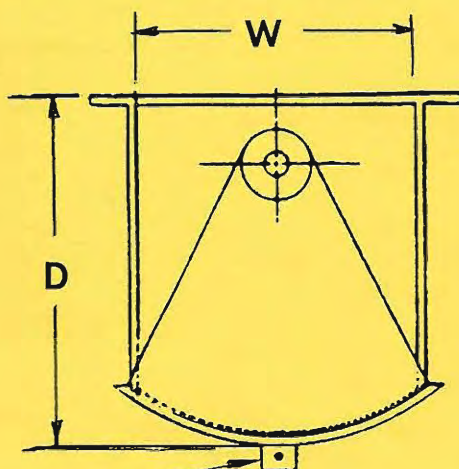

STYLE "S"

CLEVIS LUG
(By Customer)

To Obtain Quote.....Need Following Information

- ___ W Width
- ___ L Length
- ___ D Depth (Height)
- ___ T Thickness

- Bolt-On Type / Bin Gate
- ___ Style 'S' With Flange
 - ___ Style 'DG' With Flange

- Weld-On Type / Bin Gates
- ___ Style 'S' W/O Flange
 - ___ Style 'DG' W/O Flange

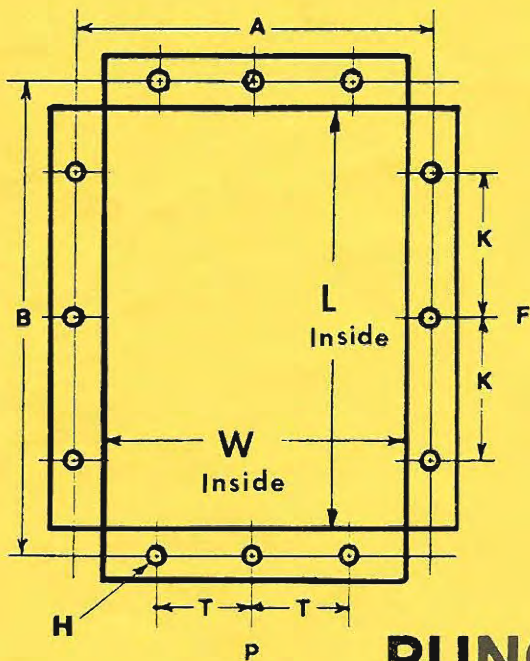

W . width across ends (inside)
P . number holes in flanges for W
T . hole centers
A . C to C of side hole lines
L . length (inside)
F . number holes in flanges for L
K . hole centers
B . C to C of end hole lines
H . size of holes

PUNCHING FOR BIN GATES

W	P	T	A	L	F	K	B	H