

C ONSTRUCTION P ARTS I NC.®

ORDER BY PHONE **TOLL FREE**
1-800-222-1141
 Ohio 1-800-338-5608
 FAX 216-524-5682 Telephone 318-524-7100

**AVAILABLE REPLACEMENT PARTS
FOR
BARBER-GREENE PLANTS**

MATERIAL: NI-HARD

PADDLE TIPS



TPS-3534

REPLACEMENT FOR
O.E.M. PART NO.
A3-2385-C
(4884)

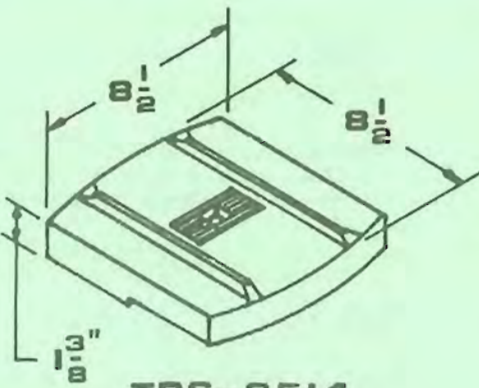

TPS-3514

REPLACEMENT FOR
O.E.M. PART NO.
A3-3855-C
(5284)

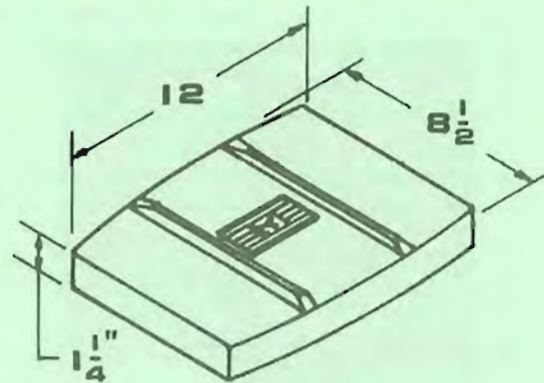

TPS-3518

REPLACEMENT FOR
O.E.M. PART NO.
A3-4241-C

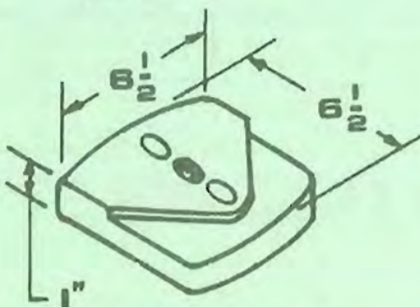

TPS-3566

REPLACEMENT FOR
O.E.M. PART NO.
A3-2948-C
(4884)

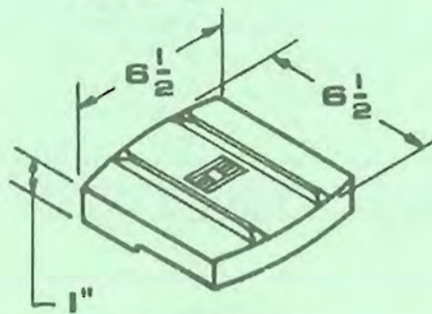

TPS-3575

REPLACEMENT FOR
O.E.M. PART NO.
A3-3739-C
(5191)

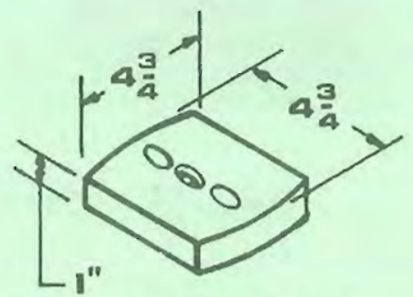

TPS-3517

REPLACEMENT FOR
O.E.M. PART NO.
A3-1974-C
A3-1051-C
(4467)

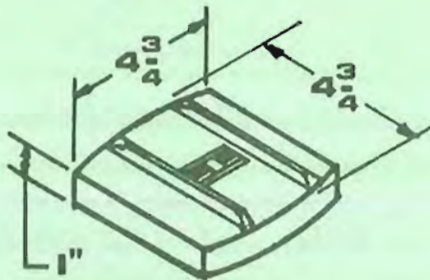

TPS-3516

REPLACEMENT FOR
O.E.M. PART NO.
A3-3840-C
(5273)

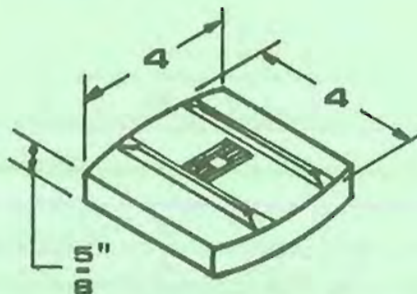

TPS-3577

REPLACEMENT FOR
O.E.M. PART NO.
A3-3946-C
(5373)

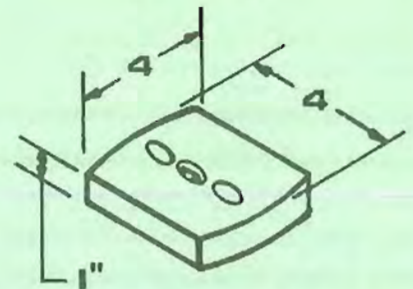

TPS-3587

REPLACEMENT FOR
O.E.M. PART NO.
A-3-1982-C
(4484)

C ONSTRUCTION P ARTS I NC.®



ORDER
BY PHONE

TOLL FREE
1-800-222-1141

Ohio 1-800-338-5608

FAX 216-524-5682

Telephone 216-524-7100

AVAILABLE REPLACEMENT PARTS
FOR
BARBER-GREENE PLANTS

PADDLE ARMS

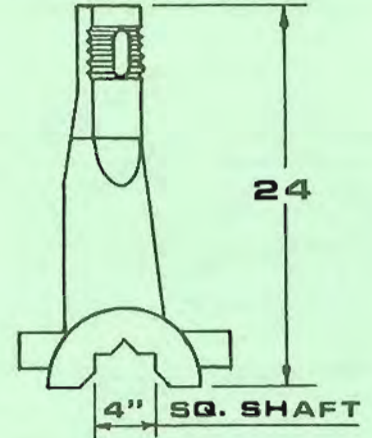
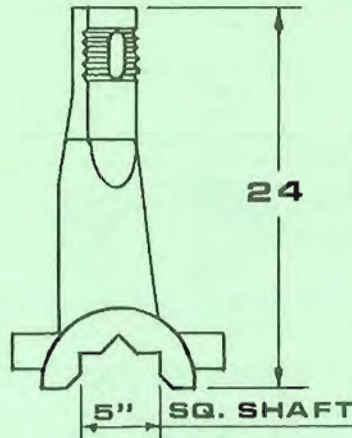
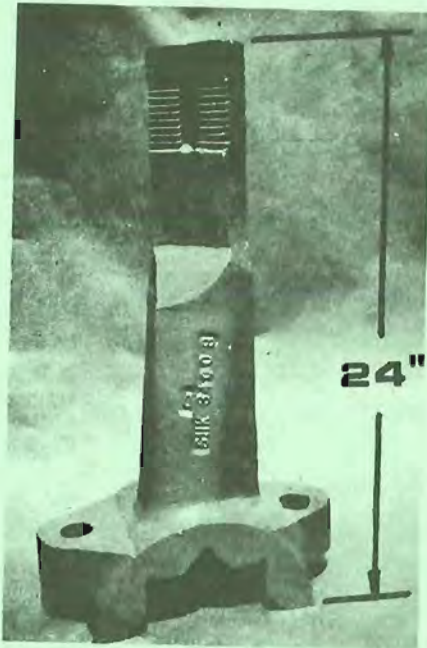

C.P.I. PART No.	REPLACEMENT FOR O.E.M. PART No.
SHK-3400-B	AB-3-3854-C D-3-3854-C
SHK-3400-C	AC-3-3854-C E-3-3854-C

C.P.I. PART No.	REPLACEMENT FOR O.E.M. PART No.
SHK-3401-E	A-1-3-3854-C B-3-3854-C
SHK-3401-D	AA-1-3-3854-C C-3-3854-C

SOLID PADDLE ARMS FOR "EXTRA WEAR"

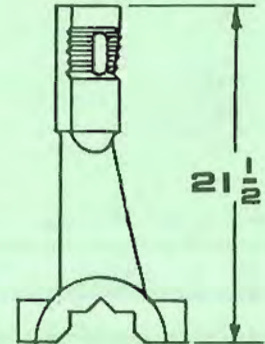
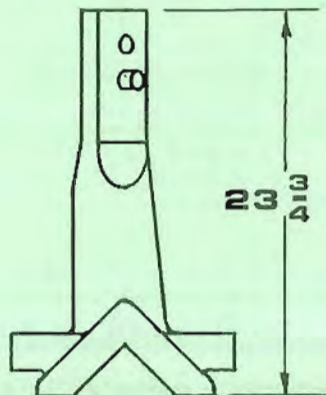
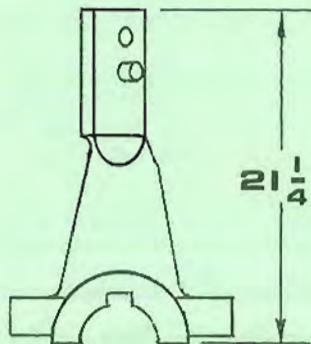

C.P.I. PART No.	REPLACEMENT FOR O.E.M. PART No.
SHK-3486-A	A-3-2635-W
SHK-3486-B	B-3-2635-W
SHK-3486-C	C-3-2635-W
SHK-3486-D	D-3-2635-W

C.P.I. PART No.	REPLACEMENT FOR O.E.M. PART No.
SHK-3489-A	A-3-2342-W (4644)
SHK-3489-C	C-3-2342-W (4645)

C.P.I. PART No.	REPLACEMENT FOR O.E.M. PART No.
SHK-3475	A-3-4125-C B-3-4125-C (5452)
SHK-3476	AA-3-4125-C C-3-4125-C (5451)

"YOUR HEADQUARTERS FOR ASPHALT PLANT REPLACEMENT PARTS"

C O N S T R U C T I O N

P A R T S

I N C. ®

P.O. BOX 43037

CLEVELAND, OHIO 44143

AVAILABLE REPLACEMENT PARTS
FOR
BARBER-GREENE PLANTS

PADDLE ARMS



ORDER
BY PHONE

TOLL FREE

1-800-222-1141

Ohio 1-800-338-5608

FAX 216-524-5682

Telephone 216-524-7100

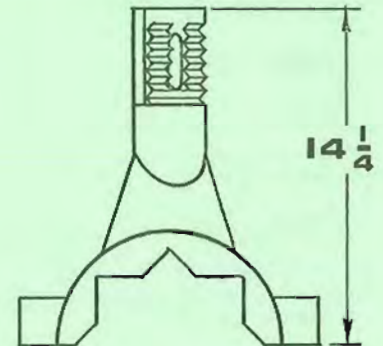
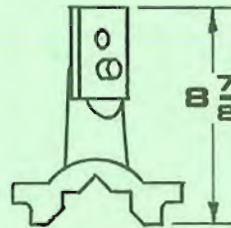
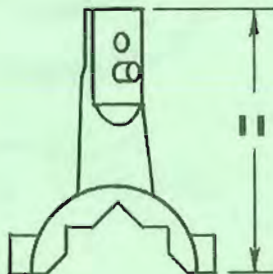

C.P.I. PART No.	REPLACEMENT FOR O.E.M. PART No.
SHK-3470-AA	AA-3-1051-C
	E-3-1051-C (3473)
SHK-3470-AB	AB-3-1051-C
	F-3-1051-C (3474)

C.P.I. PART No.	REPLACEMENT FOR O.E.M. PART No.
SHK-3481-C	A-3-1580-C
	B-3-1580-C (4219)
SHK-3481-E	AA-3-1580-C
	D-3-1580-C (4220)

C.P.I. PART No.	REPLACEMENT FOR O.E.M. PART No.
SHK-3483-A	A-3-3740-C (5192)
SHK-3483-AA	AA-3-3740-C (5193)

SOLID PADDLE ARMS FOR "EXTRA WEAR"

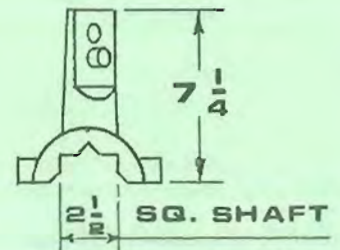
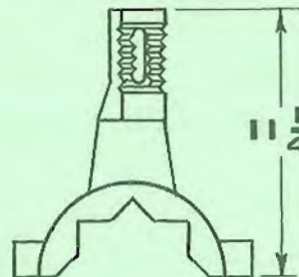
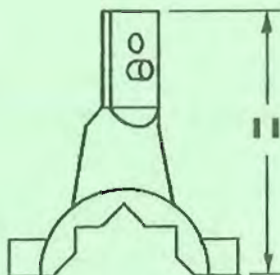

C.P.I. PART No.	REPLACEMENT FOR O.E.M. PART No.
SHK-3484-A	A-3-2392-C
	B-3-2392-C (4668)
SHK-3484-AA	AA-3-2392-C
	D-3-2392-C (4669)

C.P.I. PART No.	REPLACEMENT FOR O.E.M. PART No.
SHK-3485-A	A-3-3841-C
	B-3-3841-C (5274)
SHK-3485-AA	AA-3-3841-C
	C-3-3841-C (5275)

SPLIT PADDLE ARMS

SHK-3490-A
SHK-3490-AA

For B-G Pugmill
Model No. 824/840

"YOUR HEADQUARTERS FOR ASPHALT PLANT REPLACEMENT PARTS"

PUGMILL SEALS

SHAFT SEALS

C.P.I. PART No.	PART DESCRIPTION	REPLACEMENT FOR O.E.M. PART No.
MXP-7118	Hub	B-3-3672-C
MXP-7168	Hub	D-3-3672-C
MXP-7169	Hub	E-3-3672-C
MXP-7245	Hub	B-3-2617
MXP-7246	Hub	C-3-2617
MXP-7119	Ring	A-3-2618
MXP-7120	Ring	A-3-2627
MXP-7121	Ring	A-3-2616
MXP-7122	Ring	A-3-2615
MXP-7123	Ring	A-3-2619
MXP-7171-A	Shim	A-17-322
MXP-7171-B	Shim	B-17-322
MXP-7171-C	Shim	C-17-322

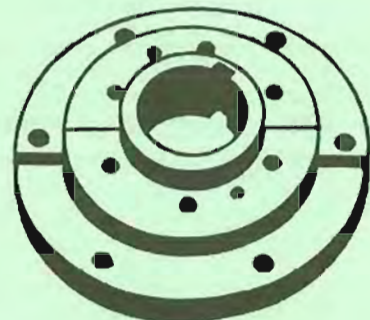

**PUGMILL
SHAFT SEAL**

AVAILABLE

Bolts For All
Pugmill Seals



**PUGMILL
LINER SEALS**

C.P.I. PART No.	REPLACEMENT FOR O.E.M. PART No.
MXP-7162-A	A-3-4200-C
MXP-7162-AA	AA-3-4200-C
MXP-7158-A	A-3-4231-C
MXP-7158-AA	AA-3-4231-C
MXP-7159-A	A-3-4232-C
MXP-7159-AA	AA-3-4232-C
MXP-7160-A	A-3-4233-C
MXP-7160-AA	AA-3-4233-C
MXP-7218-A	A-3-4234-C
MXP-7218-AA	AA-3-4234-C
MXP-7219-A	A-3-4235-C
MXP-7219-AA	AA-3-4235-C
MXP-7161-A	A-3-4426-C
MXP-7161-AA	AA-3-4426-C

C.P.I. PART No.	REPLACEMENT FOR O.E.M. PART No.
MXP-7202-A	A-3-4427-C
MXP-7202-AA	AA-3-4427-C
MXP-7172-A	A-3-4430-C
MXP-7172-AA	AA-3-4430-C
MXP-7173-A	A-3-4431-C
MXP-7173-AA	AA-3-4431-C
MXP-7163-R	DA-898-307-WR
MXP-7163-L	DA-898-307-WL
MXP-7203-CR	DA-898-307-WR
MXP-7203-CL	DA-898-307-WL
MXP-7174	DA-898-308 (D-894-497)
MXP-7204-R	898-317-WR (A-892-297-WR)
MXP-7204-L	898-317-WL (A-892-297-WL)
MXP-7180-CR	898-317-WR (A-892-297-WR)
MXP-7180-CL	898-317-WL (A-892-297-WL)
MXP-7220	D-898-318
MXP-7181	DB-898-303

C O N S T R U C T I O N P A R T S I N C .[®]



ORDER
BY PHONE

TOLL FREE
1-800-222-1141

Ohio 1-800-338-5608

FAX 216-524-5682

Telephone 216-524-7100

AVAILABLE REPLACEMENT PARTS
FOR
BARBER-GREENE PLANTS

PUGMILL PARTS

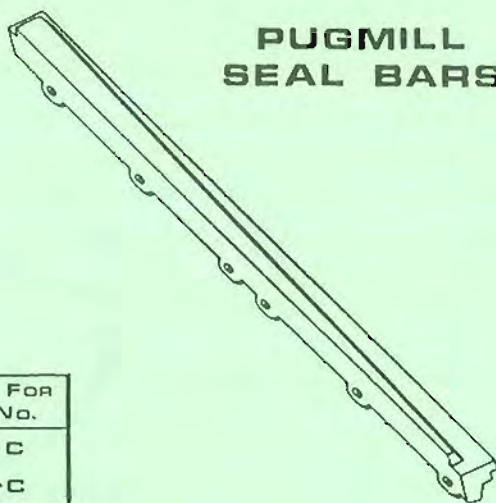
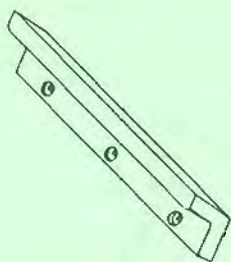

PUGMILL SEAL BARS

C.P.I. PART No.	REPLACEMENT FOR O.E.M. PART No.
MXP-7197-A	A-3-4327-C
MXP-7197-AA	AA-3-4327-C
MXP-7200-A	A-3-4326-C
MXP-7200-AA	AA-3-4326-C
MXP-7234-A SPLIT TYPE	(1) PIECE SEAL BAR
MXP-7234-AA MAKE-UP	A-3-4333-C

C.P.I. PART No.	REPLACEMENT FOR O.E.M. PART No.
MXP-7239	B1-3-3822-C
MXP-7240	B1-3-4023-C

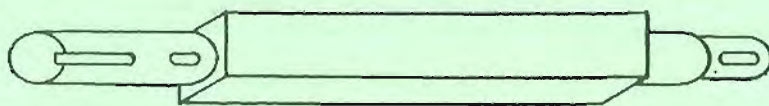

PUGMILL SHAFTS

C.P.I. PART No.	PART DESCRIPTION	REPLACEMENT FOR O.E.M. PART No.
MXP-7241	Pugmill Shaft	BA-898-312
MXP-7256	Pugmill Shaft	EB-898-322
MXP-7257	Pugmill Shaft	EA-898-308
MXP-7274	Pugmill Shaft	EA-898-303

"YOUR HEADQUARTERS FOR ASPHALT PLANT REPLACEMENT PARTS"

C O N S T R U C T I O N P A R T S I N C.[®]



ORDER
BY PHONE

TOLL FREE
1-800-222-1141

Ohio 1-800-338-5608

FAX 216-524-5682

Telephone 216-524-7100

**AVAILABLE REPLACEMENT PARTS
FOR
BARBER-GREENE PLANTS**

PUGMILL PARTS

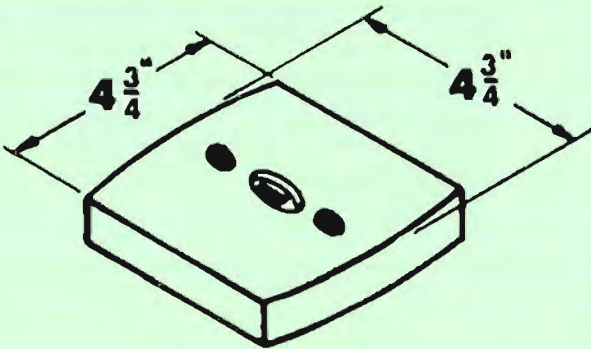

PADDLE TIP

Part No.

TPS-3517

Replacement for O.E.M.
Part No. A3-1974-C (4467)

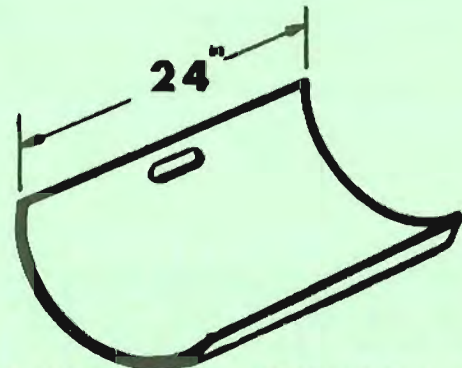

PUGMILL SHELL LINER

Part No.

LNR-2414

Replacement for O.E.M.
Part No. B-848-65W

PUGMILL SHELL LINERS - MODELS 828 AND 848

C.P.I.
PART NO.

PART DESCRIPTION

O.E.M.
PART NO.

LNR-2453

Upper Curved Liner

BG-848-L1

LNR-2454

Lower Curved Liner

BG-848-L2

"YOUR HEADQUARTERS FOR ASPHALT PLANT REPLACEMENT PARTS"



ORDER BY PHONE
TOLL FREE
1-800-222-1141
Ohio 1-800-338-5608
FAX 216-524-5682 Telephone 216-524-7100

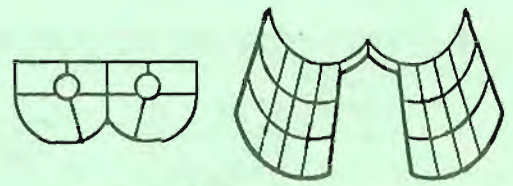

PUGMILL LINERS

AVAILABLE REPLACEMENT PARTS FOR BARBER-GREENE PLANTS

PADDLE TIPS

C.P.I. PART No.	REPLACEMENT FOR O.E.M. PART No.
TPS-3517	4467
TPS-3587	4484
TPS-3534	4664
TPS-3575	5191
TPS-3516	5273
TPS-3514	5284

C.P.I. PART No.	REPLACEMENT FOR O.E.M. PART No.
LNR-2578-A	4709
LNR-2578-AA	4710
LNR-2460-A	4711
LNR-2460-AA	4712
LNR-2461-A	4713
LNR-2461-AA	4714
LNR-2579-A	4715
LNR-2579-AA	4716
LNR-2580-A	4717
LNR-2581-A	4718
LNR-2582-A	4719
LNR-2582-AA	4720
LNR-2559-A	4721
LNR-2559-AA	4722
LNR-2560-A	4723
LNR-2560-AA	4724
LNR-2455-A1	4725
LNR-2455-A2	

C.P.I. PART No.	REPLACEMENT FOR O.E.M. PART No.
LNR-2588-A	4830
LNR-2588-AA	4831
LNR-2589-A	4832
LNR-2589-AA	4833
LNR-2590-A	4834
LNR-2590-AA	4835
LNR-2456-A	4873
LNR-2724-A	4874
LNR-2591-A	4886
LNR-2591-AA	4887

PADDLE ARMS

C.P.I. PART No.	REPLACEMENT FOR O.E.M. PART No.
SHK-3470-AA	3473
SHK-3470-AB	3474
SHK-3481-C	4219
SHK-3481-E	4220
SHK-3489-A	4644
SHK-3489-C	4645
SHK-3484-A	4668
SHK-3484-AA	4669
SHK-3483-A	5192
SHK-3483-AA	5193
SHK-3485-A	5274
SHK-3485-AA	5275
SHK-3476	5451
SHK-3475	5452

LNR-2577-A	4725
LNR-2638-A	4748
LNR-2638-AA	4749
LNR-2637-A	4750
LNR-2637-AA	4751
LNR-2646-A	4753
LNR-2646-AA	4754
LNR-2647-A	4755
LNR-2647-AA	4756
LNR-2462-A	4808
LNR-2462-AA	4809
LNR-2463-A	4810
LNR-2463-AA	4811
LNR-2583-A	4812
LNR-2458-A	4813
LNR-2723-A	4820
LNR-2723-AA	4821
LNR-2585-A	4824
LNR-2586-A	4825
LNR-2587-A	4828
LNR-2587-AA	4829

LNR-2470-A	4991
LNR-2470-AA	4992
LNR-2457-A	5214
LNR-2457-AA	5215
LNR-2459-A	5247
LNR-2459-AA	5248
LNR-2515-A	5263
LNR-2516-A	5264
LNR-2628-A	5265
LNR-2464-A	5270
LNR-2471-A	5330
LNR-2471-AA	5331
LNR-2472-A	5332
LNR-2472-AA	5333
LNR-2597-A	5428
LNR-2598-A	5433
LNR-2598-AA	5434
LNR-2599-A	5435
LNR-2599-AA	5436
LNR-2602-A	5437
LNR-2602-AA	5438
LNR-2593-A	5439
LNR-2593-AA	5440
LNR-2594-A	5441
LNR-2594-AA	5442
LNR-2595-A	5443
LNR-2595-AA	5444
LNR-2596-A	5445
LNR-2596-AA	5446
LNR-2603-A	5448
LNR-2604-A	5449

"YOUR HEADQUARTERS FOR ASPHALT PLANT REPLACEMENT PARTS"



ORDER BY PHONE **TOLL FREE**
1-800-222-1141
Ohio 1-800-338-5608
FAX 216-524-5682 Telephone 216-524-7100



PUGMILL LINERS

AVAILABLE REPLACEMENT PARTS FOR BARBER-GREENE PLANTS

C.P.I. PART No.	REPLACEMENT FOR O.E.M. PART No.	C.P.I. PART No.	REPLACEMENT FOR O.E.M. PART No.	C.P.I. PART No.	REPLACEMENT FOR O.E.M. PART No.
LNR-2578-A	A-3-2591-C	LNR-2647-A	A-3-2658-C	LNR-2591-A	A-3-2964-C
LNR-2578-AA	AA-3-2591-C	LNR-2647-AA	AA-3-2658-C	LNR-2591-AA	AA-3-2964-C
LNR-2460-A	A-3-2593-C	LNR-2462-A	A-3-2837-C	LNR-2470-A	A-3-3299-C
LNR-2460-AA	AA-3-2593-C	LNR-2462-AA	AA-3-2837-C	LNR-2470-AA	AA-3-3299-C
LNR-2461-A	A-3-2594-C	LNR-2463-A	A-3-2838-C	LNR-2457-A	A-3-3762-C
LNR-2461-AA	AA-3-2594-C	LNR-2463-AA	AA-3-2838-C	LNR-2457-AA	AA-3-3762-C
LNR-2579-A	A-3-2602-C	LNR-2583-A	A-3-2839-C	LNR-2459-A	A-3-3804-C
LNR-2579-AA	AA-3-2602-C	LNR-2458-A	A-3-2840-C	LNR-2459-AA	AA-3-3804-C
LNR-2580-A	A-3-2603-C	LNR-2584-A	A-3-2841-C	LNR-2515-A	A-3-3825-C
LNR-2581-A	A-3-2604-C	LNR-2584-A	B-3-2841-C	LNR-2516-A	A-3-3826-C
LNR-2582-A	A-3-2605-C	LNR-2723-A	A-3-2848-C	LNR-2628-A	A-3-3827-C
LNR-2582-AA	AA-3-2605-C	LNR-2723-AA	AA-3-2848-C	LNR-2464-A	A-3-3836-C
LNR-2559-A	A-3-2606-C	LNR-2585-A	A-3-2853-C	LNR-2644-A	A-3-3914-C
LNR-2559-AA	AA-3-2606-C	LNR-2585-A	B-3-2853-C	LNR-2644-AA	AA-3-3914-C
LNR-2560-A	A-3-2607-C	LNR-2586-A	A-3-3854-C	LNR-2645-A1	A-3-3914-C
LNR-2560-AA	AA-3-2607-C	LNR-2587-A	A-3-2857-C	LNR-2645-A2	A-3-3914-C
LNR-2455-A1	A-3-2608-C	LNR-2587-A	B-3-2857-C	LNR-2645-AA1	AA-3-3914-C
LNR-2455-A2	A-3-2608-C	LNR-2587-AA	AA-3-2857-C	LNR-2645-AA2	AA-3-3914-C
LNR-2577-A	A-3-2608-C	LNR-2587-AA	C-3-2857-C	LNR-2471-A	A-3-3915-C
LNR-2638-A	A-3-2653-C	LNR-2588-A	A-3-2858-C	LNR-2471-AA	AA-3-3915-C
LNR-2638-AA	AA-3-2653-C	LNR-2588-AA	AA-3-2858-C	LNR-2472-A	A-3-3916-C
LNR-2637-A	A-3-2654-C	LNR-2589-A	A-3-2859-C	LNR-2472-AA	AA-3-3916-C
LNR-2637-AA	AA-3-2654-C	LNR-2589-AA	AA-3-2859-C		
LNR-2646-A	A-3-2657-C	LNR-2590-A	A-3-2860-C		
LNR-2646-AA	AA-3-2657-C	LNR-2590-AA	AA-3-2860-C		
		LNR-2456-A	A-3-2916-C		
		LNR-2724-A	A-3-2922-C		

"YOUR HEADQUARTERS FOR ASPHALT PLANT REPLACEMENT PARTS"



ORDER BY PHONE

TOLL FREE 1-800-222-1141

Ohio 1-800-338-5608

FAX 216-524-5682

Telephone 216-524-7100

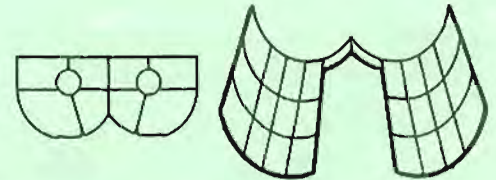

PUGMILL LINERS

AVAILABLE REPLACEMENT PARTS FOR BARBER-GREENE PLANTS

C.P.I. PART No.	REPLACEMENT FOR O.E.M. PART No.	C.P.I. PART No.	REPLACEMENT FOR O.E.M. PART No.	C.P.I. PART No.	REPLACEMENT FOR O.E.M. PART No.
LNR-2684-A	A-3-4019-C	LNR-2469-A	A-3-4320-C	Check w/CPI	A-3-4425-C
LNR-2684-AA	AA-3-4019-C	LNR-2469-AA	AA-3-4320-C		AA-3-4425-C
LNR-2597-A	A-3-4034-C	LNR-2474-A	A-3-4321-C	Check w/CPI	A-3-4428-C
LNR-2669-A	A-3-4036-C	LNR-2474-AA	AA-3-4321-C		AA-3-4428-C
LNR-2675-A	A-3-4037-C	LNR-2606-A	A-3-4322-C	Check w/CPI	A-3-4435-C
LNR-2615-A	A-3-4038-C	LNR-2606-AA	AA-3-4322-C		AA-3-4435-C
LNR-2670-A	A-3-4039-C	LNR-2467-A	A-3-4323-C	LNR-2629-A	A-3-4585-C
LNR-2598-A	A-3-4040-C	LNR-2467-AA	AA-3-4323-C	LNR-2629-AA	AA-3-4585-C
LNR-2598-AA	AA-3-4040-C	LNR-2466-A	A-3-4324-C	LNR-2645-A1	A-3-4586-C
LNR-2599-A	A-3-4041-C	LNR-2466-AA	AA-3-4324-C	LNR-2645-A2	AA-3-4586-C
LNR-2599-AA	AA-3-4041-C	LNR-2465-A	A-3-4325-C	LNR-2624-A	A-3-4587-C
LNR-2602-A	A-3-4042-C	LNR-2465-AA	AA-3-4325-C	LNR-2624-AA	AA-3-4587-C
LNR-2602-AA	AA-3-4042-C	LNR-2475-A	A-3-4331-C	LNR-2625-A	A-3-4588-C
LNR-2593-A	A-3-4043-C	LNR-2475-AA	AA-3-4331-C	LNR-2625-AA	AA-3-4588-C
LNR-2593-AA	AA-3-4043-C	LNR-2476-A	A-3-4332-C	LNR-2642-A	A-3-4589-C
LNR-2594-A	A-3-4044-C	LNR-2476-AA	AA-3-4332-C	LNR-2642-AA	AA-3-4589-C
LNR-2594-AA	AA-3-4044-C	LNR-2600-A	A-3-4337-C	LNR-2643-A	A-3-4590-C
LNR-2595-A	A-3-4045-C	LNR-2600-AA	AA-3-4337-C	LNR-2643-AA	AA-3-4590-C
LNR-2595-AA	AA-3-4045-C	LNR-2601-A	A-3-4338-C	LNR-2626-A	A-3-4591-C
LNR-2596-A	A-3-4046-C	LNR-2601-AA	AA-3-4338-C	LNR-2626-AA	AA-3-4591-C
LNR-2596-AA	AA-3-4046-C	LNR-2612-A	A-3-4357-C	LNR-2627-A	A-3-4592-C
LNR-2603-A	A-3-4048-C	LNR-2612-AA	AA-3-4357-C	LNR-2627-AA	AA-3-4592-C
LNR-2604-A	A-3-4049-C	LNR-2613-A	A-3-4358-C	LNR-2706-A	A-3-4595-C
LNR-2480-A	A-3-4184-C B-3-4184-C	LNR-2613-AA	AA-3-4358-C	LNR-2706-AA	AA-3-4595-C
LNR-2480-AA	AA-3-4184-C C-3-4184-C	LNR-2630-A	A-3-4360-C	LNR-2707-A	A-3-4596-C
		LNR-2631-A	A-3-4361-C	LNR-2707-AA	AA-3-4596-C
		LNR-2632-A	A-3-4362-C	LNR-2716-A	A-3-4597-C
		Check w/CPI	A-3-4424-C	LNR-2716-AA	AA-3-4597-C
			AA-3-4424-C	LNR-2717-A	A-3-4598-C
				LNR-2717-AA	AA-3-4598-C

"YOUR HEADQUARTERS FOR ASPHALT PLANT REPLACEMENT PARTS"

C O N S T R U C T I O N P A R T S I N C . ®



ORDER
BY PHONE

TOLL FREE
1-800-222-1141

Ohio 1-800-338-5608

FAX 216-524-5682

Telephone 216-524-7100

AVAILABLE REPLACEMENT PARTS
FOR
BARBER-GREENE PLANTS

PUGMILL GATE LINERS

MATERIAL: NI-HARD

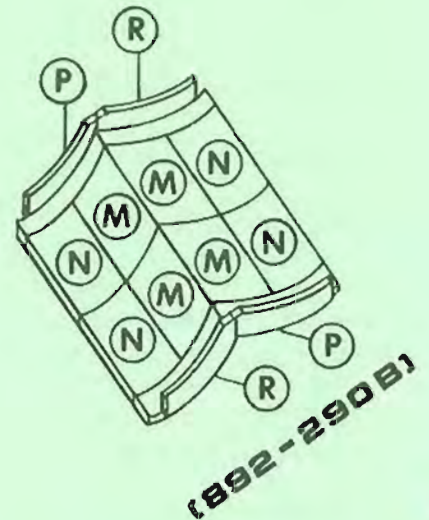
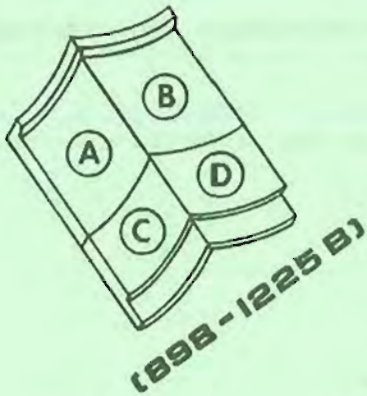

REF.	C.P.I. PART No.	PART DESCRIPTION	REPLACEMENT FOR O.E.M. PART No.
A	LNR-2612-A	Gate Liner	A-3-4357-C
B	LNR-2612-AA	Gate Liner	AA-3-4357-C
C	LNR-2613-A	Gate Liner	A-3-4358-C
D	LNR-2613-AA	Gate Liner	AA-3-4358-C
E	LNR-2600-A	Gate Liner	A-3-4337-C
F	LNR-2600-AA	Gate Liner	AA-3-4337-C
G	LNR-2601-A	Gate Liner	A-3-4338-C
H	LNR-2601-AA	Gate Liner	AA-3-4338-C
J	LNR-2458-A	Gate Liner	A-3-2840-C (#4813)
K	LNR-2584-A	Gate Liner	A-3-2841-C (#4814)
L	MXP-7174	Mixer Seal Liner	DA-898-308
M	LNR-2735-A	Gate Liner	A-3-2849-C (#4822)
N	LNR-2736-A	Gate Liner	A-3-2850-C (#4823)
P	MXP-7204-WL	Mixer Seal	A-892-297-WL
R	MXP-7204-WR	Mixer Seal	A-892-297-WR

"YOUR HEADQUARTERS FOR ASPHALT PLANT REPLACEMENT PARTS"

C ONSTRUCTION P ARTS I NC.®



ORDER
BY PHONE

TOLL FREE
1-800-222-1141

Ohio 1-800-338-5608

FAX 216-524-5682

Telephone 216-524-7100

AVAILABLE REPLACEMENT PARTS
FOR
BARBER-GREENE PLANTS

PUGMILL GATE LINERS

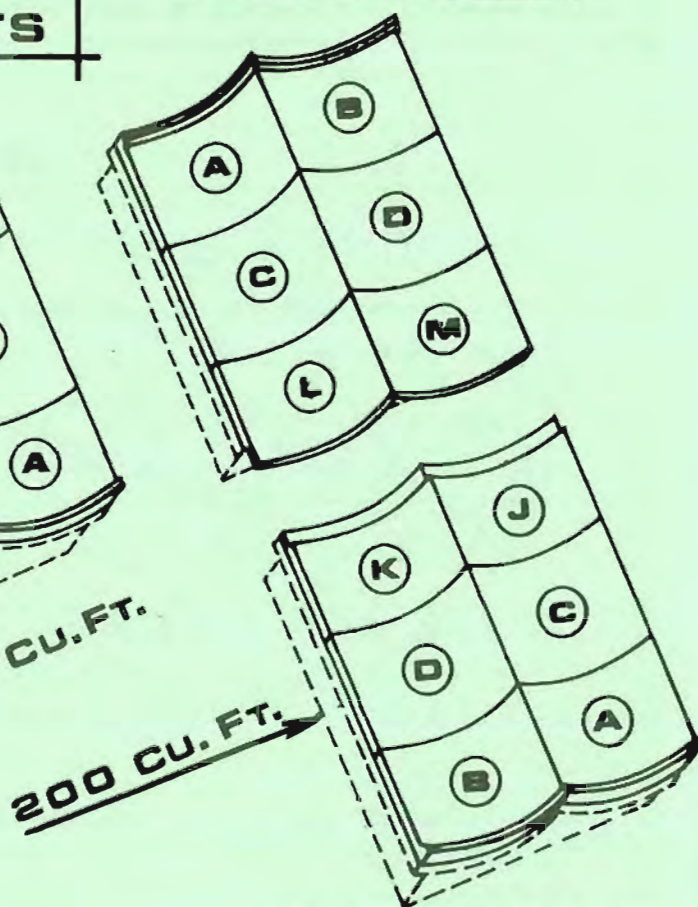
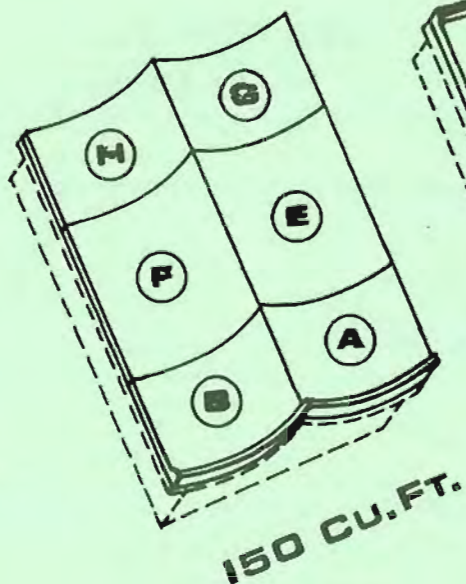
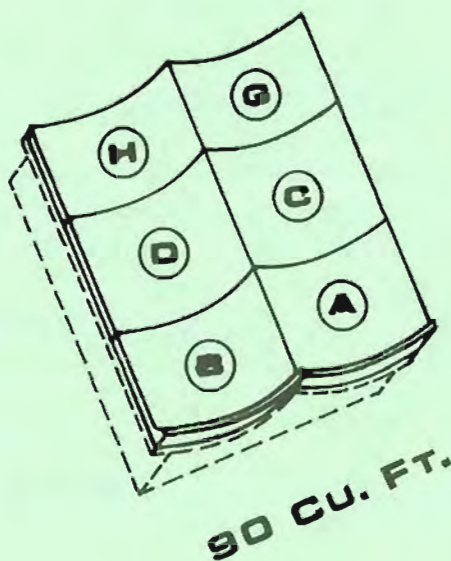

MATERIAL: NI-HARD

REF.	C.P.I. PART NO.	PART DESCRIPTION	REPLACEMENT FOR O.E.M. PART NO.
A	LNR-2469-A	Gate Liner	A-3-4320-C
B	LNR-2469-AA	Gate Liner	AA-3-4320-C
C	LNR-2474-A	Gate Liner	A-3-4321-C
D	LNR-2474-AA	Gate Liner	AA-3-4321-C
E	LNR-2467-A	Gate Liner	A-3-4323-C
F	LNR-2467-AA	Gate Liner	AA-3-4323-C
G	LNR-2466-A	Gate Liner	A-3-4324-C
H	LNR-2466-AA	Gate Liner	AA-3-4324-C
J	LNR-2475-A	Gate Liner	A-3-4331-C
K	LNR-2475-AA	Gate Liner	AA-3-4331-C
L	LNR-2476-A	Gate Liner	A-3-4332-C
M	LNR-2476-AA	Gate Liner	AA-3-4332-C

"YOUR HEADQUARTERS FOR ASPHALT PLANT REPLACEMENT PARTS"

CONSTRUCTION PARTS INC.®



ORDER
BY PHONE

TOLL FREE
1-800-222-1141

Ohio 1-800-338-5608

FAX 216-524-5682

Telephone 216-524-7100

**AVAILABLE REPLACEMENT PARTS
FOR
BARBER-GREENE PLANTS**

**PUGMILL
GATE LINERS**

MODEL 894 & 896

**MATERIAL:
NI-HARD**

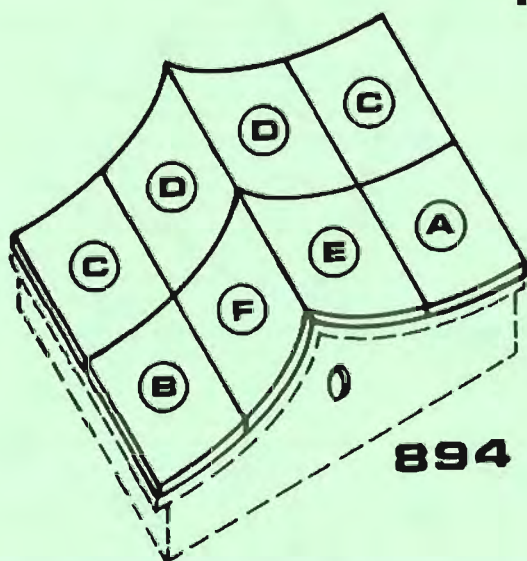

894

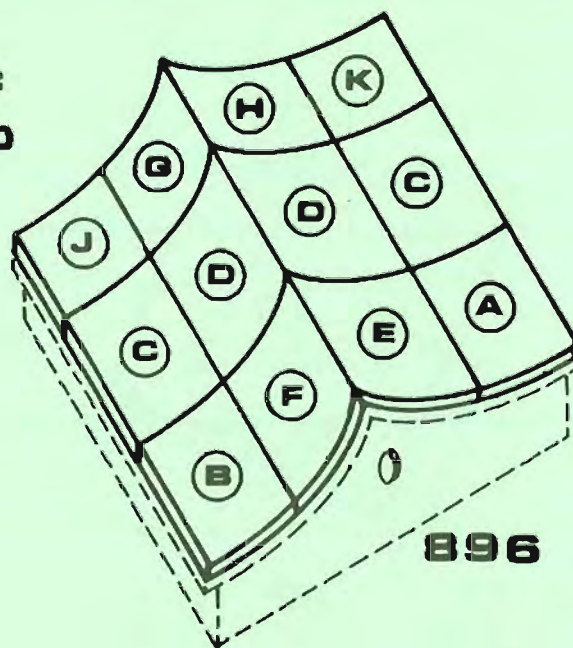

896

REF.	C.P.I. PART NO.	PART DESCRIPTION	REPLACEMENT FOR O.E.M. PART NO.
A	LNR-2579-A	Gate Liner	A-3-2602-C (#4715)
B	LNR-2579-AA	Gate Liner	AA-3-2602-C (#4716)
C	LNR-2580-A	Gate Liner	A-3-2603-C (#4717)
D	LNR-2581-A	Gate Liner	A-3-2604-C (#4718)
E	LNR-2582-A	Gate Liner	A-3-2605-C (#4719)
F	LNR-2582-AA	Gate Liner	AA-3-2605-C (#4720)
G	LNR-2646-A	Gate Liner	A-3-2657-C (#4753)
H	LNR-2646-AA	Gate Liner	AA-3-2657-C (#4754)
J	LNR-2647-A	Gate Liner	A-3-2658-C (#4755)
K	LNR-2647-AA	Gate Liner	AA-3-2658-C (#4756)

"YOUR HEADQUARTERS FOR ASPHALT PLANT REPLACEMENT PARTS"

C O N S T R U C T I O N P A R T S I N C. ®



ORDER
BY PHONE

TOLL FREE
1-800-222-1141

Ohio 1-800-338-5608

FAX 216-524-5682

Telephone 216-524-7100

AVAILABLE REPLACEMENT PARTS
FOR
BARBER-GREENE PLANTS

PUGMILL LINERS
(892 - 136 B)

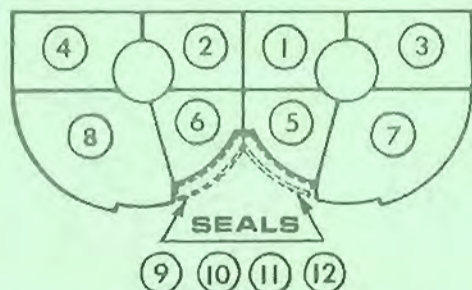

END LINERS

MATERIAL:
NI-HARD

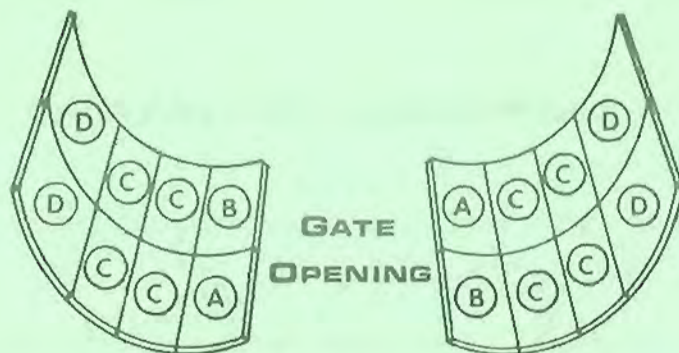

SHELL LINERS

REF.	C.P.I. PART NO.	PART DESCRIPTION	REPLACEMENT FOR O.E.M. PART No.
A	LNR-2723-A	Shell Liner	A-3-2848-C (#4885)
B	LNR-2723-AA	Shell Liner	AA-3-2848-C (#4821)
C	LNR-2724-A	Shell Liner	A-3-2922-C (#4874)
D	LNR-2734-A	Shell Liner	A-3-2632-C (#4736)
1	LNR-2681-A	End Liner	A-3-2629-C (#4730)
2	LNR-2681-AA	End Liner	AA-3-2629-C (#4731)
3	LNR-2733-A	End Liner	A-3-2628-C (#4728)
4	LNR-2733-AA	End Liner	AA-3-2628-C (#4729)
5	LNR-2732-A	End Liner - Split	A-3-2847-C (#4819)
6	LNR-2732-AA	End Liner - Split	AA-3-2847-C (#4820)
7	LNR-2731-A	End Liner - Split	A-3-2846-C (#4817)
8	LNR-2731-AA	End Liner - Split	AA-3-2846-C (#4818)
9	MXP-7158-A	Mixer Seal	A-3-4231-C
10	MXP-7158-AA	Mixer Seal	AA-3-4231-C
11	MXP-7159-A	Mixer Seal	A-3-4232-C
12	MXP-7159-AA	Mixer Seal	AA-3-4232-C

"YOUR HEADQUARTERS FOR ASPHALT PLANT REPLACEMENT PARTS"





ORDER BY PHONE **TOLL FREE**
1-800-222-1141
 Ohio 1-800-338-5608
 Telephone 216-524-7100
 FAX 216-524-5682

AVAILABLE REPLACEMENT PARTS FOR BARBER-GREENE PLANTS

PUGMILL LINERS MODEL No. 894

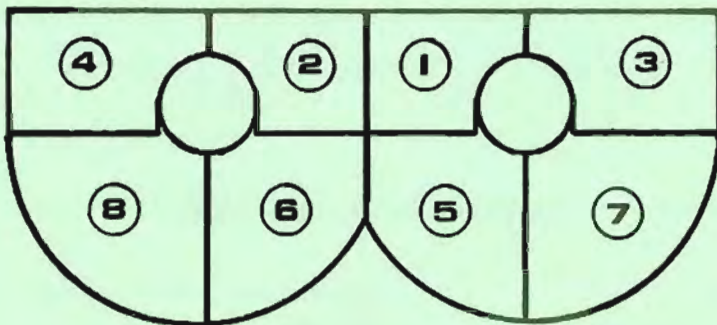
MATERIAL: NI-HARD



END LINERS

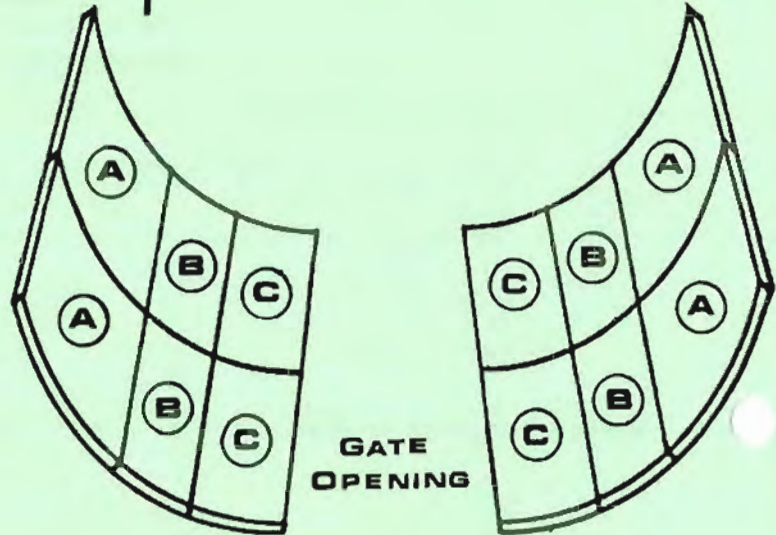

SHELL LINERS

REF.	C.P.I. PART No.	PART DESCRIPTION	REPLACEMENT FOR O.E.M. PART No.
A	LNR-2577-A	Shell Liner	A-3-2608-C (#4725)
B	LNR-2578-A	Shell Liner	A-3-2591-C (#4709)
C	LNR-2578-AA	Shell Liner	AA-3-2591-C (#4710)
1	LNR-2460-A	End Liner	A-3-2593-C (#4711)
2	LNR-2460-AA	End Liner	AA-3-2593-C (#4712)
3	LNR-2461-A	End Liner	A-3-2594-C (#4713)
4	LNR-2461-AA	End Liner	AA-3-2594-C (#4714)
5	LNR-2560-A	End Liner	A-3-2607-C (#4723)
6	LNR-2560-AA	End Liner	AA-3-2607-C (#4724)
7	LNR-2559-A	End Liner	A-3-2606-C (#4721)
8	LNR-2559-AA	End Liner	AA-3-2606-C (#4722)

"YOUR HEADQUARTERS FOR ASPHALT PLANT REPLACEMENT PARTS"

CONSTRUCTION PARTS INC.®



ORDER
BY PHONE

TOLL FREE
1-800-222-1141

Ohio 1-800-338-5608

FAX 216-524-5682

Telephone 216-524-7100

AVAILABLE REPLACEMENT PARTS
FOR
BARBER-GREENE PLANTS

**PUGMILL LINERS
MODEL No. 894-25B**

MATERIAL: NI-HARD

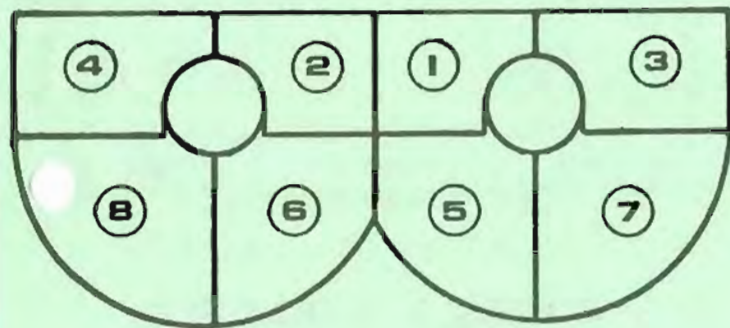

END LINERS

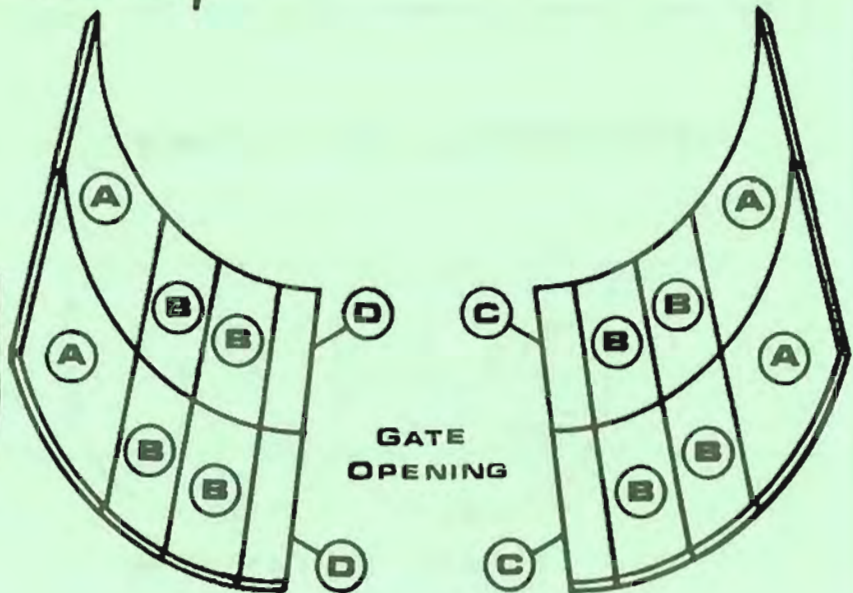

SHELL LINERS

REF.	C.P.I. PART No.	PART DESCRIPTION	REPLACEMENT FOR O.E.M. PART No.
A	LNR-2577-A	Shell Liner	A-3-2608-C (#4725)
B	LNR-2456-A	Shell Liner	A-3-2916-C (#4873)
C	LNR-2591-A	Shell Liner	A-3-2964-C (#4886)
D	LNR-2591-AA	Shell Liner	AA-3-2964-C (#4887)
1	LNR-2460-A	End Liner	A-3-2593-C (#4711)
2	LNR-2460-AA	End Liner	AA-3-2593-C (#4712)
3	LNR-2461-A	End Liner	A-3-2594-C (#4713)
4	LNR-2461-AA	End Liner	AA-3-2594-C (#4714)
5	LNR-2462-A	End Liner	A-3-2837-C (#4808)
6	LNR-2462-AA	End Liner	AA-3-2837-C (#4809)
7	LNR-2463-A	End Liner	A-3-2838-C (#4810)
8	LNR-2463-AA	End Liner	AA-3-2838-C (#4811)

"YOUR HEADQUARTERS FOR ASPHALT PLANT REPLACEMENT PARTS"



ORDER BY PHONE

TOLL FREE
1-800-222-1141

Ohio 1-800-338-5608

FAX 216-524-5682

Telephone 216-524-7100

AVAILABLE REPLACEMENT PARTS
FOR
BARBER-GREENE PLANTS

PUGMILL LINERS
MODEL No. 896

MATERIAL: NI-HARD

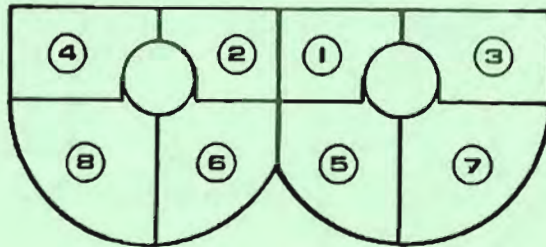

END LINERS

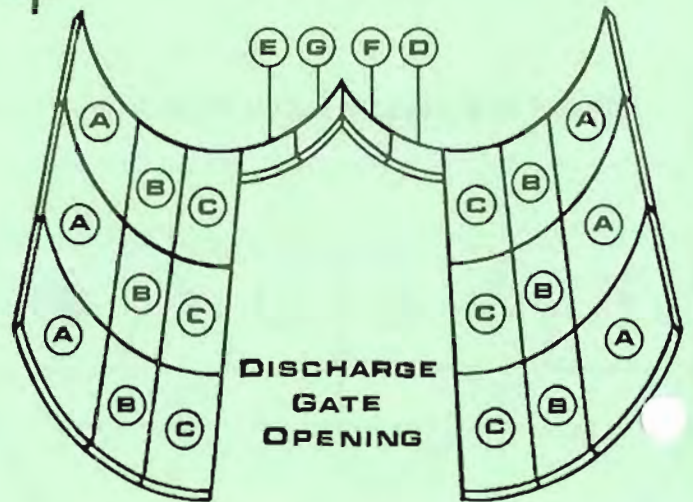

SHELL LINERS

REF.	C.P.I. PART No.	PART DESCRIPTION	REPLACEMENT FOR O.E.M. PART No.
A	LNR-2577-A	Shell Liner	A-3-2608-C (#4725)
B	LNR-2578-A	Shell Liner	A-3-2591-C (#4709)
C	LNR-2578-AA	Shell Liner	AA-3-2591-C (#4710)
D	LNR-2637-A	Shell Liner	A-3-2654-C (#4750)
E	LNR-2637-AA	Shell Liner	AA-3-2654-C (#4751)
F	LNR-2638-A	Shell Liner	A-3-2653-C (#4748)
G	LNR-2638-AA	Shell Liner	AA-3-2653-C (#4749)
1	LNR-2460-A	End Liner	A-3-2593-C (#4711)
2	LNR-2460-AA	End Liner	AA-3-2593-C (#4712)
3	LNR-2461-A	End Liner	A-3-2594-C (#4713)
4	LNR-2461-AA	End Liner	AA-3-2594-C (#4714)
5	LNR-2560-A	End Liner	A-3-2607-C (#4723)
6	LNR-2560-AA	End Liner	AA-3-2607-C (#4724)
7	LNR-2559-A	End Liner	A-3-2606-C (#4721)
8	LNR-2559-AA	End Liner	AA-3-2606-C (#4722)

"YOUR HEADQUARTERS FOR ASPHALT PLANT REPLACEMENT PARTS"

C O N S T R U C T I O N P A R T S I N C .[®]



ORDER
BY PHONE

TOLL FREE
1-800-222-1141

Ohio 1-800-338-5608

FAX 216-524-5682

Telephone 216-524-7100

AVAILABLE REPLACEMENT PARTS
FOR
BARBER-GREENE PLANTS

PUGMILL LINERS
90 CU. F. PUGMILL
(898-1225 B)

MATERIAL: NI-HARD

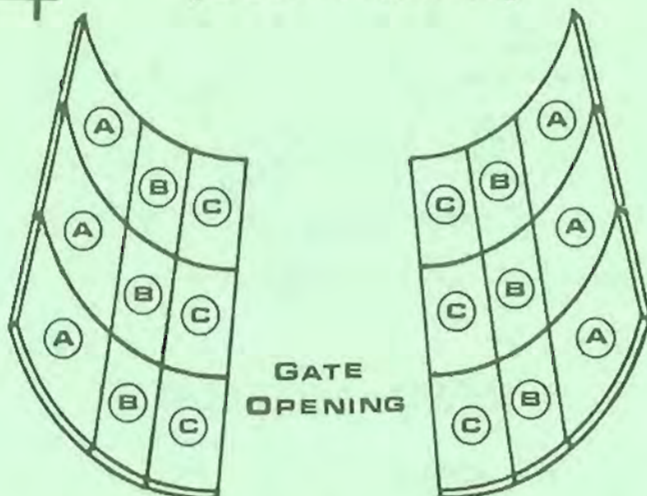
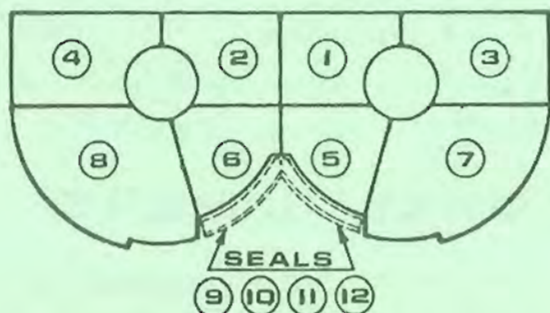

END LINERS

SHELL LINERS

REF.	C.P.I. PART No.	PART DESCRIPTION	REPLACEMENT FOR O.E.M. PART No.
A	LNR-2632-A	Shell Liner	A-3-4362-C
B	LNR-2630-A	Shell Liner	A-3-4360-C
C	LNR-2631-A	Shell Liner	A-3-4361-C
1	LNR-2593-A	End Liner	A-3-4043-C (#5439)
2	LNR-2593-AA	End Liner	AA-3-4043-C (#5440)
3	LNR-2594-A	End Liner	A-3-4044-C (#5441)
4	LNR-2594-AA	End Liner	AA-3-4044-C (#5442)
5	LNR-2596-A	End Liner	A-3-4046-C (#5445)
6	LNR-2596-AA	End Liner	AA-3-4046-C (#5446)
7		End Liner	A-3-4435-C
8	Check With C.P.I.	End Liner	AA-3-4435-C
9	MXP-7172-A	Mixer Seal	A-3-4430-C
10	MXP-7172-AA	Mixer Seal	AA-3-4430-C
11	MXP-7173-A	Mixer Seal	A-3-4431-C
12	MXP-7173-AA	Mixer Seal	AA-3-4431-C

"YOUR HEADQUARTERS FOR ASPHALT PLANT REPLACEMENT PARTS"



ORDER
BY PHONE

TOLL FREE
1-800-222-1141

Ohio 1-800-338-5608

FAX 216-524-5682

Telephone 314-524-7100

AVAILABLE REPLACEMENT PARTS
FOR
BARBER-GREENE PLANTS

PUGMILL LINERS

(898-3908)

MATERIAL:
NI-HARD

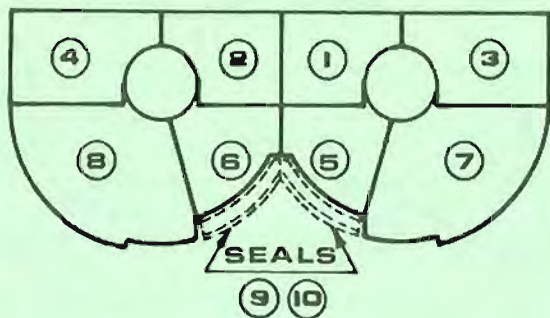

END LINERS

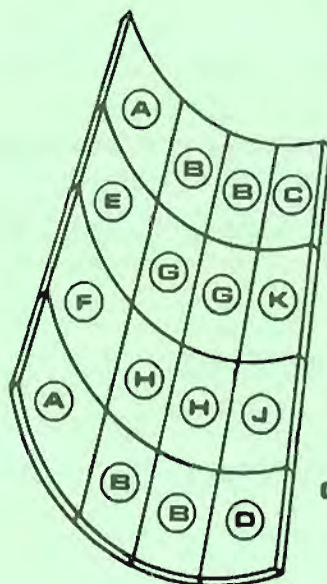

GATE
OPENING

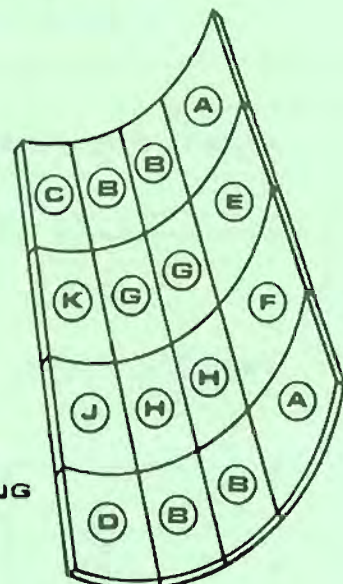

SHELL LINERS

REF.	C.P.I. PART No.	PART DESCRIPTION	REPLACEMENT FOR O.E.M. PART No.
A	LNR-2577-A	Shell Liner	A-3-2608-C (#4725)
B	LNR-2456-A	Shell Liner	A-3-2916-C (#4873)
C	LNR-2459-A	Shell Liner	A-3-3804-C (#5247)
D	LNR-2459-AA	Shell Liner	AA-3-3804-C (#5248)
E	LNR-2644-A	Shell Liner	A-3-3914-C
F	LNR-2644-AA	Shell Liner	AA-3-3914-C
G	LNR-2471-A	Shell Liner	A-3-3915-C (#5330)
H	LNR-2471-AA	Shell Liner	AA-3-3915-C (#5331)
J	LNR-2472-A	Shell Liner	A-3-3916-C (#5332)
K	LNR-2472-AA	Shell Liner	AA-3-3916-C (#5333)
1	LNR-2460-A	End Liner	A-3-2593-C (#4711)
2	LNR-2460-AA	End Liner	AA-3-2593-C (#4712)
3	LNR-2461-A	End Liner	A-3-2594-C (#4713)
4	LNR-2461-AA	End Liner	AA-3-2594-C (#4714)
5	LNR-2462-A	End Liner	A-3-2837-C (#4808)
6	LNR-2462-AA	End Liner	AA-3-2837-C (#4809)
7	LNR-2463-A	End Liner	A-3-2838-C (#4810)
8	LNR-2463-AA	End Liner	AA-3-2838-C (#4811)
9	MXP-7160-A	Mixer Seal	A-3-4233-C
10	MXP-7160-AA	Mixer Seal	AA-3-4233-C

"YOUR HEADQUARTERS FOR ASPHALT PLANT REPLACEMENT PARTS"



ORDER
BY PHONE

TOLL FREE
1-800-222-1141

Ohio 1-800-338-5608

FAX 216-524-5682

Telephone 216-524-7100

AVAILABLE REPLACEMENT PARTS
FOR
BARBER-GREENE PLANTS

PUGMILL LINERS

(898-320B)

MATERIAL: NI-HARD

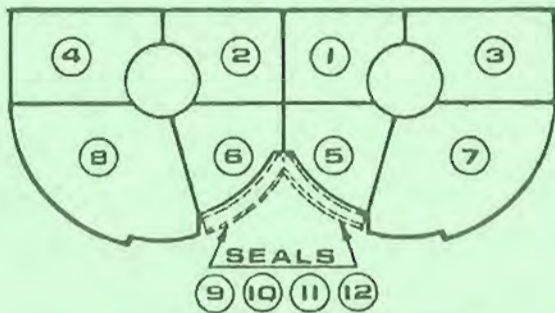

END LINERS

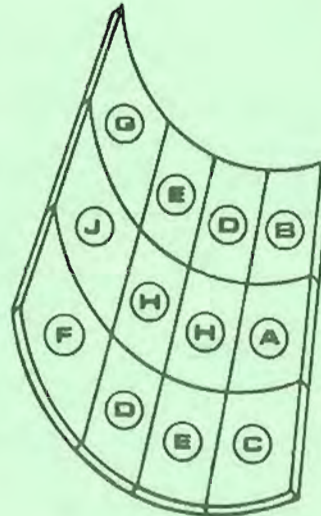

GATE
OPENING

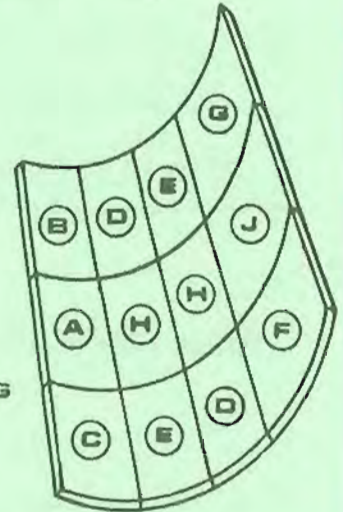

SHELL LINERS

REF.	C.P.I. PART No.	PART DESCRIPTION	REPLACEMENT FOR O.E.M. PART No.
A	LNR-2597-A	Shell Liner	A-3-4034-C (#5428)
B	LNR-2598-A	Shell Liner	A-3-4040-C (#5433)
C	LNR-2598-AA	Shell Liner	AA-3-4040-C (#5434)
D	LNR-2599-A	Shell Liner	A-3-4041-C (#5435)
E	LNR-2599-AA	Shell Liner	AA-3-4041-C (#5436)
F	LNR-2602-A	Shell Liner	A-3-4042-C (#5437)
G	LNR-2602-AA	Shell Liner	AA-3-4042-C (#5438)
H	LNR-2603-A	Shell Liner	A-3-4048-C (#5448)
J	LNR-2604-A	Shell Liner	A-3-4049-C (#5449)
1	LNR-2593-A	End Liner	A-3-4043-C (#5439)
2	LNR-2593-AA	End Liner	AA-3-4043-C (#5440)
3	LNR-2594-A	End Liner	A-3-4044-C (#5441)
4	LNR-2594-AA	End Liner	AA-3-4044-C (#5442)
5	LNR-2596-A	End Liner	A-3-4046-C (#5445)
6	LNR-2596-AA	End Liner	AA-3-4046-C (#5446)
7	LNR-2595-A	End Liner	A-3-4045-C (#5443)
8	LNR-2595-AA	End Liner	AA-3-4045-C (#5444)
	Check With C.P.I.	End Liner	A-3-4429-C
		End Liner	AA-3-4429-C
9	MXP-7158-A	Mixer Seal	A-3-4231-C
10	MXP-7158-AA	Mixer Seal	AA-3-4231-C
11	MXP-7159-A	Mixer Seal	A-3-4232-C
12	MXP-7159-AA	Mixer Seal	AA-3-4232-C

"YOUR HEADQUARTERS FOR ASPHALT PLANT REPLACEMENT PARTS"

C O N S T R U C T I O N P A R T S I N C. ®



ORDER
BY PHONE

TOLL FREE
1-800-222-1141

Ohio 1-800-338-5608

FAX 216-524-5682

Telephone 216-524-7100

AVAILABLE REPLACEMENT PARTS
FOR
BARBER-GREENE PLANTS

PUGMILL LINERS
(898-3108)

MATERIAL: NI-HARD

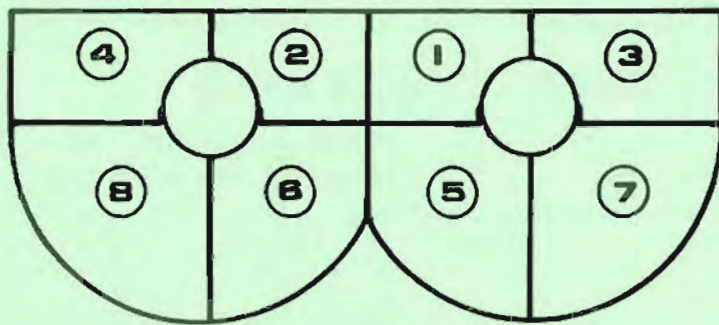

END LINERS

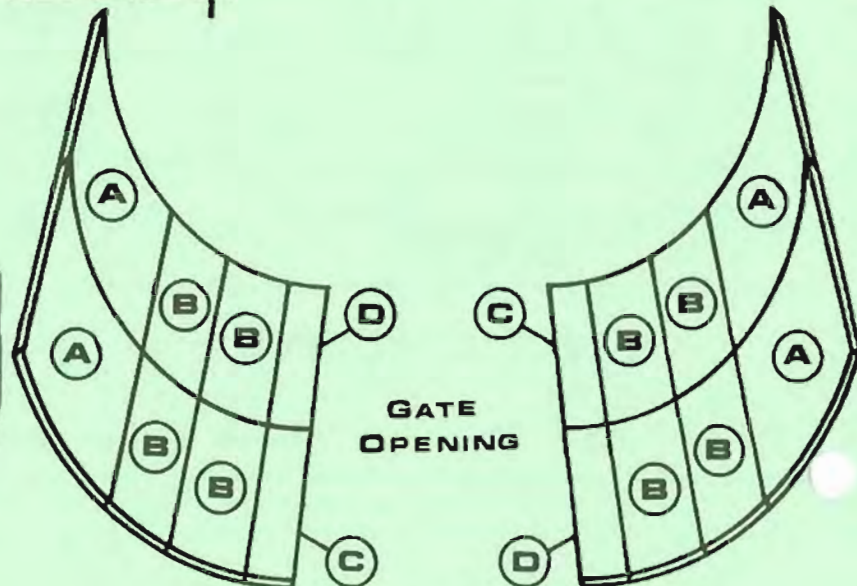

SHELL LINERS

REF.	C.P.I. PART No.	PART DESCRIPTION	REPLACEMENT FOR O.E.M. PART No.
A	LNR-2577-A	Shell Liner	A-3-2608-C (#4725)
B	LNR-2456-A	Shell Liner	A-3-2916-C (#4873)
C	LNR-2459-A	Shell Liner	A-3-3804-C (#5247)
D	LNR-2459-AA	Shell Liner	AA-3-3804-C (#5248)
1	LNR-2460-A	End Liner	A-3-2593-C (#4711)
2	LNR-2460-AA	End Liner	AA-3-2593-C (#4712)
3	LNR-2461-A	End Liner	A-3-2594-C (#4713)
4	LNR-2461-AA	End Liner	AA-3-2594-C (#4714)
5	LNR-2462-A	End Liner	A-3-2837-C (#4808)
6	LNR-2462-AA	End Liner	AA-3-2837-C (#4809)
7	LNR-2463-A	End Liner	A-3-2838-C (#4810)
8	LNR-2463-AA	End Liner	AA-3-2838-C (#4811)
	MXP-7163-L	Mixer Seal	DA-898-307-WL
	MXP-7163-R	Mixer Seal	DA-898-307-WR
	MXP-7174	Mixer Seal	DA-898-308 (D-894-497)

"YOUR HEADQUARTERS FOR ASPHALT PLANT REPLACEMENT PARTS"

PUGMILL LINERS
150 Cu. Ft. PUGMILL
(898-305B)

MATERIAL:
NI-HARD Inter-changeable Arrangement #1

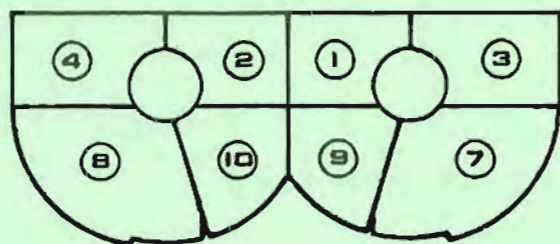
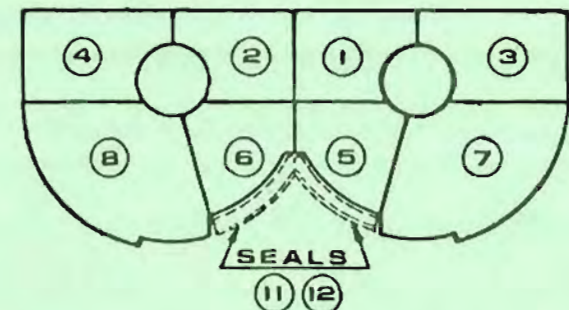

END LINERS

SHELL LINERS

REF.	C.P.I. PART No.	PART DESCRIPTION	REPLACEMENT FOR O.E.M. PART No.
A	LNR-2577-A	Shell Liner	A-3-2608-C (#4725)
B	LNR-2456-A	Shell Liner	A-3-2916-C (#4873)
C	LNR-2459-A	Shell Liner	A-3-3804-C (#5247)
D	LNR-2459-AA	Shell Liner	AA-3-3804-C (#5248)
E	LNR-2464-A	Shell Liner	A-3-3836-C (#5270)
F	LNR-2465-A	Shell Liner	A-3-4325-C
G	LNR-2465-AA	Shell Liner	AA-3-4325-C
1	LNR-2460-A	End Liner	A-3-2593-C (#4711)
2	LNR-2460-AA	End Liner	AA-3-2593-C (#4712)
3	LNR-2461-A	End Liner	A-3-2594-C (#4713)
4	LNR-2461-AA	End Liner	AA-3-2594-C (#4714)
5	Check With C.P.I.	End Liner	A-3-4424-C
6		End Liner	AA-3-4424-C
7	Check With C.P.I.	End Liner	A-3-4425-C
8		End Liner	AA-3-4425-C
9	Check With C.P.I.	End Liner	A-3-4428-C
10		End Liner	AA-3-4428-C
11	MXP-7161-A	Mixer Seal	A-3-4426-C
12	MXP-7161-AA	Mixer Seal	AA-3-4426-C

"YOUR HEADQUARTERS FOR ASPHALT PLANT REPLACEMENT PARTS"



ORDER
BY PHONE

TOLL FREE
1-800-222-1141

Ohio 1-800-338-5608

FAX 216-524-5682

Telephone 216-524-7100

AVAILABLE REPLACEMENT PARTS
FOR
BARBER-GREENE PLANTS

PUGMILL LINERS

150 CU. FT. PUGMILL

(898-305B)

MATERIAL:

NI-HARD Inter-changeable Arrangement #2

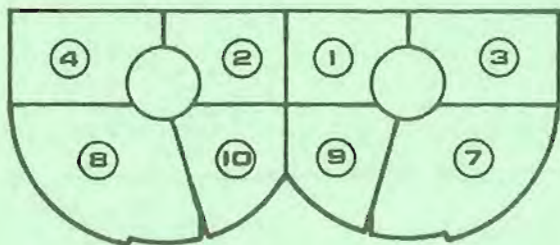
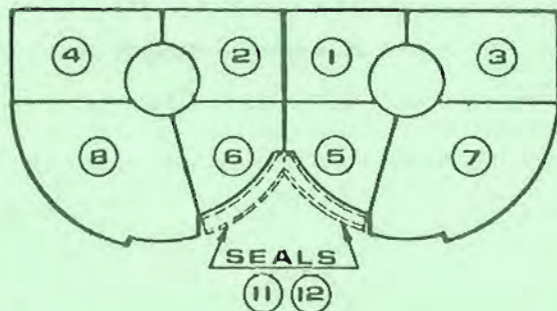

END LINERS

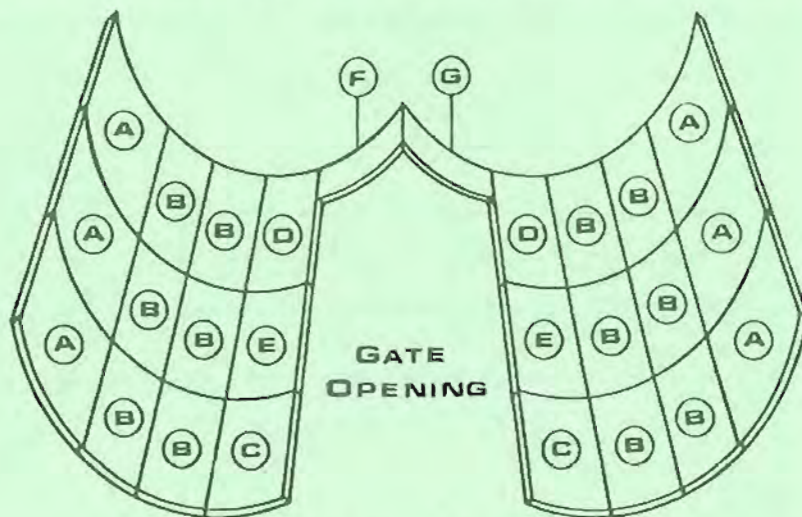

SHELL LINERS

REF.	C.P.I. PART NO.	PART DESCRIPTION	REPLACEMENT FOR O.E.M. PART NO.
A	LNR-2577-A	Shell Liner	A-3-2608-C (#4725)
B	LNR-2456-A	Shell Liner	A-3-2916-C (#4873)
C	LNR-2459-A	Shell Liner	A-3-3804-C (#5247)
D	LNR-2459-AA	Shell Liner	AA-3-3804-C (#5248)
E	LNR-2464-A	Shell Liner	A-3-3836-C (#5270)
F	LNR-2465-A	Shell Liner	A-3-4325-C
G	LNR-2465-AA	Shell Liner	AA-3-4325-C
1	LNR-2460-A	End Liner	A-3-2593-C (#4711)
2	LNR-2460-AA	End Liner	AA-3-2593-C (#4712)
3	LNR-2461-A	End Liner	A-3-2594-C (#4713)
4	LNR-2461-AA	End Liner	AA-3-2594-C (#4714)
5	LNR-2462-A	End Liner	A-3-2837-A (#4808)
6	LNR-2462-AA	End Liner	AA-3-2837-C (#4809)
7	LNR-2463-A	End Liner	A-3-2838-C (#4810)
8	LNR-2463-AA	End Liner	AA-3-2838-C (#4811)
9	LNR-2470-A	End Liner	A-3-3299-C (#4991)
10	LNR-2470-AA	End Liner	AA-3-3299-C (#4992)
11	MXP-7160-A	Mixer Seal	A-3-4233-C
12	MXP-7160-AA	Mixer Seal	AA-3-4233-C

"YOUR HEADQUARTERS FOR ASPHALT PLANT REPLACEMENT PARTS"

ORDER BY PHONE **TOLL FREE 1-800-222-1141**
Ohio 1-800-338-5608
FAX 216-524-5682 Telephone 316-524-7100

AVAILABLE REPLACEMENT PARTS
FOR
BARBER-GREENE PLANTS

PUGMILL LINERS
150CU. FT. PUGMILL
(898-305B)

MATERIAL: NI-HARD Inter-changeable Arrangement #3

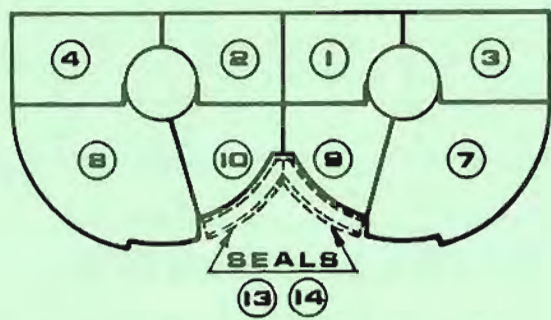
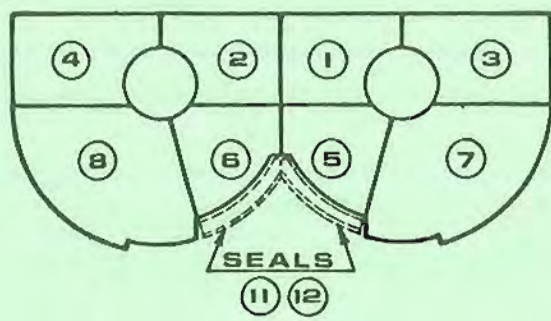

END LINERS

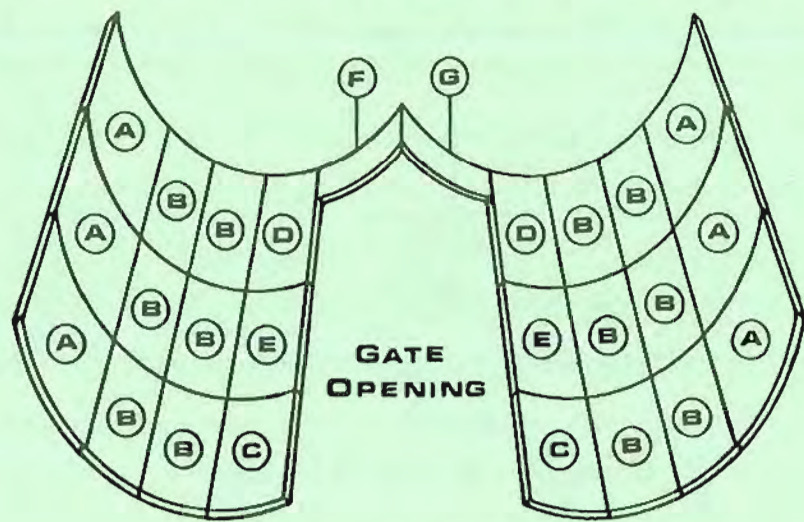

SHELL LINERS

REF.	C.P.I. PART No.	PART DESCRIPTION	REPLACEMENT FOR O.E.M. PART No.
A	LNR-2577-A	Shell Liner	A-3-2608-C (#4725)
B	LNR-2456-A	Shell Liner	A-3-2916-C (#4873)
C	LNR-2459-A	Shell Liner	A-3-3804-C (#5247)
D	LNR-2459-AA	Shell Liner	AA-3-3804-C (#5248)
E	LNR-2464-A	Shell Liner	A-3-3836-C (#5270)
F	LNR-2465-A	Shell Liner	A-3-4325-C
G	LNR-2465-AA	Shell Liner	AA-3-4325-C
1	LNR-2460-A	End Liner	A-3-2593-C (#4711)
2	LNR-2460-AA	End Liner	AA-3-2593-C (#4712)
3	LNR-2461-A	End Liner	A-3-2594-C (#4713)
4	LNR-2461-AA	End Liner	AA-3-2594-C (#4714)
5	LNR-2462-A	End Liner	A-3-2837-A (#4808)
6	LNR-2462-AA	End Liner	AA-3-2837-C (#4809)
7	LNR-2463-A	End Liner	A-3-2838-C (#4810)
8	LNR-2463-AA	End Liner	AA-3-2838-C (#4811)
9	LNR-2470-A	End Liner	A-3-3299-C (#4991)
10	LNR-2470-AA	End Liner	AA-3-3299-C (#4992)
11	MXP-7160-A	Mixer Seal	A-3-4233-C
12	MXP-7160-AA	Mixer Seal	AA-3-4233-C
13	MXP-7161-A	Mixer Seal	A-3-4426-C
14	MXP-7161-AA	Mixer Seal	AA-3-4426-C

"YOUR HEADQUARTERS FOR ASPHALT PLANT REPLACEMENT PARTS"

ORDER BY PHONE
TOLL FREE
1-800-222-1141
Ohio 1-800-338-5608
FAX 216-524-5682 Telephone 216-524-7100

AVAILABLE REPLACEMENT PARTS
FOR
BARBER-GREENE PLANTS
PUGMILL LINERS
150 CU. FT. PUGMILL

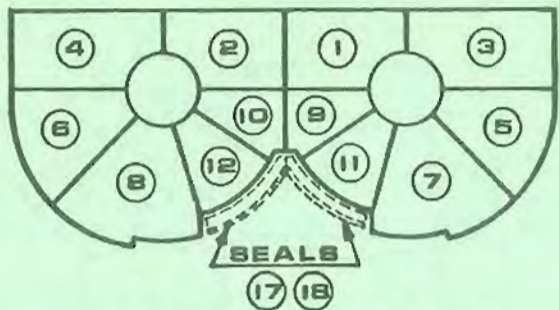
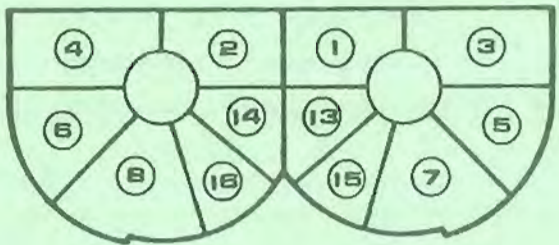

END LINERS

MATERIAL:
NI-HARD

(898-305B)
Inter-changeable Arrangement #4

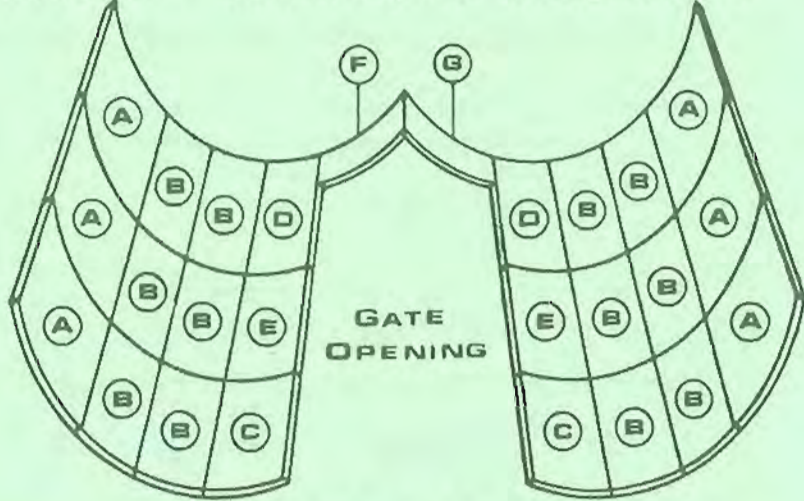

SHELL LINERS

REF.	C.P.I. PART No.	PART DESCRIPTION	REPLACEMENT FOR O.E.M. PART No.
A	LNR-2577-A	Shell Liner	A-3-2608-C (#472)
B	LNR-2456-A	Shell Liner	A-3-2916-C (#4873)
C	LNR-2459-A	Shell Liner	A-3-3804-C (#5247)
D	LNR-2459-AA	Shell Liner	AA-3-3804-C (#5248)
E	LNR-2464-A	Shell Liner	A-3-3836-C (#5270)
F	LNR-2465-A	Shell Liner	A-3-4325-C
G	LNR-2465-AA	Shell Liner	AA-3-4325-C
1	LNR-2460-A	End Liner	A-3-2593-C (#4711)
2	LNR-2460-AA	End Liner	AA-3-2593-C (#4712)
3	LNR-2461-A	End Liner	A-3-2594-C (#4713)
4	LNR-2461-AA	End Liner	AA-3-2594-C (#4714)
5	LNR-2624-A	End Liner	A-3-4587-C
6	LNR-2624-AA	End Liner	AA-3-4587-C
7	LNR-2625-A	End Liner	A-3-4588-C
8	LNR-2625-AA	End Liner	AA-3-4588-C
9	LNR-2642-A	End Liner	A-3-4589-C
10	LNR-2642-AA	End Liner	AA-3-4589-C
11	LNR-2643-A	End Liner	A-3-4590-C
12	LNR-2643-AA	End Liner	AA-3-4590-C
13	LNR-2626-A	End Liner	A-3-4591-C
14	LNR-2626-AA	End Liner	AA-3-4591-C
15	LNR-2627-A	End Liner	A-3-4592-C
16	LNR-2627-AA	End Liner	AA-3-4592-C
17	MXP-7161-A	Mixer Seal	A-3-4426-C
18	MXP-7161-AA	Mixer Seal	AA-3-4426-C

"YOUR HEADQUARTERS FOR ASPHALT PLANT REPLACEMENT PARTS"



ORDER
BY PHONE

TOLL FREE
1-800-222-1141

Ohio 1-800-338-5608

FAX 216-524-5682

Telephone 216-224-7100

AVAILABLE REPLACEMENT PARTS
FOR
BARBER-GREENE PLANTS

PUGMILL LINERS

150 CU. FT. PUGMILL

(898-305B)

Inter-changeable Arrangement #5

MATERIAL:
NI-HARD

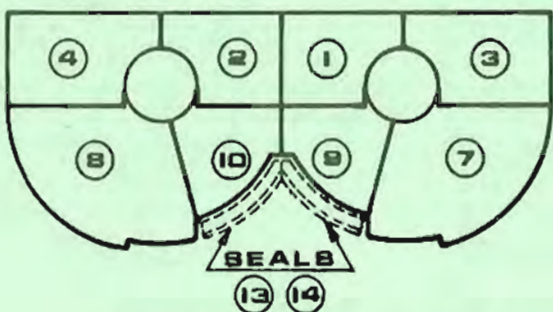
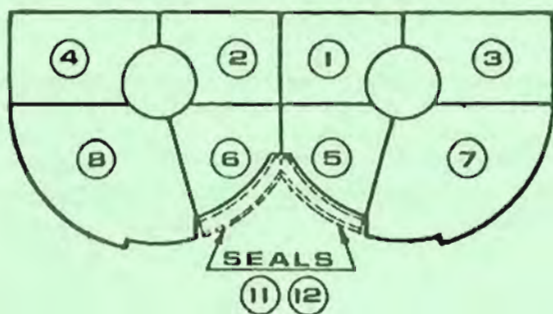

END LINERS



SHELL LINERS

REF.	C.P.I. PART No.	PART DESCRIPTION	REPLACEMENT FOR O.E.M. PART No.
A	LNR-2629-A	Shell Liner	A-3-4585-C
AA	LNR-2629-AA	Shell Liner	AA-3-4585-C
B	LNR-2456-A	Shell Liner	A-3-2916-C (#4873)
C	LNR-2459-A	Shell Liner	A-3-3804-C (#5247)
D	LNR-2459-AA	Shell Liner	AA-3-3804-C (#5248)
E	LNR-2464-A	Shell Liner	A-3-3836-C (#5270)
F	LNR-2465-A	Shell Liner	A-3-4325-C
G	LNR-2465-AA	Shell Liner	AA-3-4325-C
1	LNR-2460-A	End Liner	A-3-2593-C (#4711)
2	LNR-2460-AA	End Liner	AA-3-2593-C (#4712)
3	LNR-2461-A	End Liner	A-3-2594-C (#4713)
4	LNR-2461-AA	End Liner	AA-3-2594-C (#4714)
5	LNR-2462-A	End Liner	A-3-2837-A (#4808)
6	LNR-2462-AA	End Liner	AA-3-2837-C (#4809)
7	LNR-2463-A	End Liner	A-3-2838-C (#4810)
8	LNR-2463-AA	End Liner	AA-3-2838-C (#4811)
9	LNR-2470-A	End Liner	A-3-3299-C (#4991)
10	LNR-2470-AA	End Liner	AA-3-3299-C (#4992)
11	MXP-7160-A	Mixer Seal	A-3-4233-C
12	MXP-7160-AA	Mixer Seal	AA-3-4233-C
13	MXP-7161-A	Mixer Seal	A-3-4426-C
14	MXP-7161-AA	Mixer Seal	AA-3-4426-C

"YOUR HEADQUARTERS FOR ASPHALT PLANT REPLACEMENT PARTS"

ORDER BY PHONE **TOLL FREE 1-800-222-1141**
Ohio 1-800-338-5608
FAX 216-524-5682 Telephone 216-324-7100

AVAILABLE REPLACEMENT PARTS
FOR
BARBER-GREENE PLANTS

PUGMILL LINERS
150 CU. FT. PUGMILL

MATERIAL: NI-HARD
(898-305B)
Inter-changeable Arrangement #6

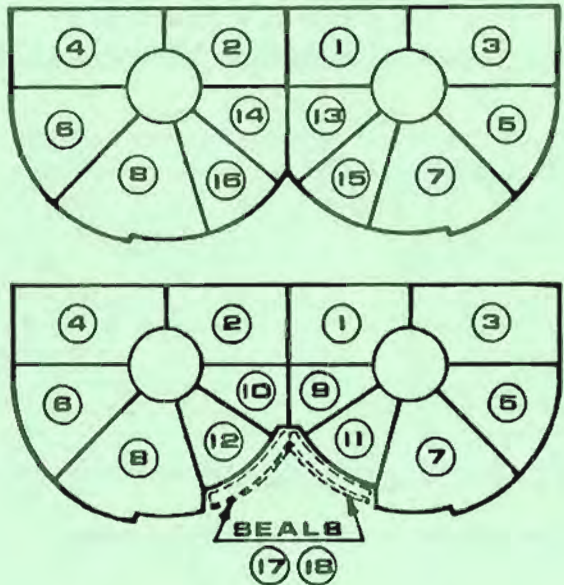

END LINERS

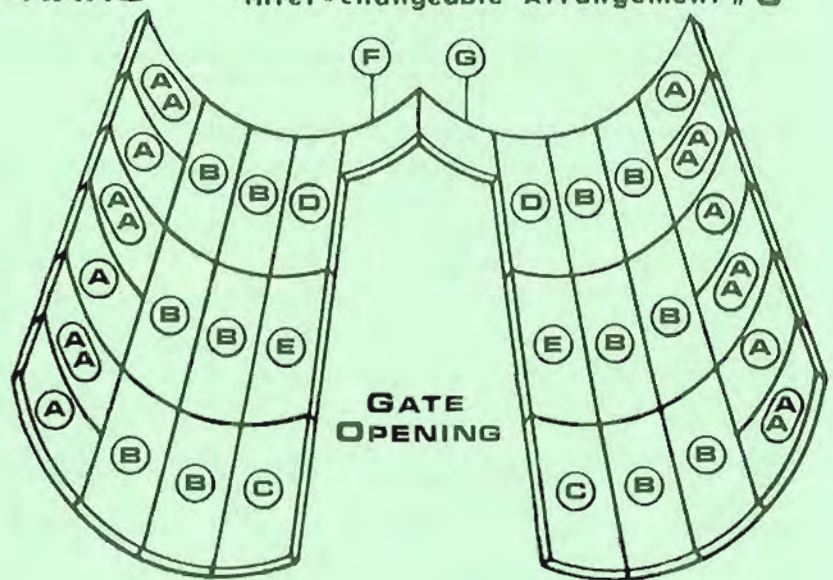

SHELL LINERS

REF.	C.P.I. PART No.	PART DESCRIPTION	REPLACEMENT FOR O.E.M. PART No.
A	LNR-2577-A	Shell Liner	A-3-2608-C (#4725)
B	LNR-2456-A	Shell Liner	A-3-2916-C (#4873)
C	LNR-2459-A	Shell Liner	A-3-3804-C (#5247)
D	LNR-2459-AA	Shell Liner	AA-3-3804-C (#5248)
E	LNR-2464-A	Shell Liner	A-3-3836-C (#5270)
F	LNR-2465-A	Shell Liner	A-3-4325-C
G	LNR-2465-AA	Shell Liner	AA-3-4325-C
1	LNR-2460-A	End Liner	A-3-2593-C (#4711)
2	LNR-2460-AA	End Liner	AA-3-2593-C (#4712)
3	LNR-2461-A	End Liner	A-3-2594-C (#4713)
4	LNR-2461-AA	End Liner	AA-3-2594-C (#4714)
5	LNR-2624-A	End Liner	A-3-4587-C
6	LNR-2624-AA	End Liner	AA-3-4587-C
7	LNR-2625-A	End Liner	A-3-4588-C
8	LNR-2625-AA	End Liner	AA-3-4588-C
9	LNR-2642-A	End Liner	A-3-4589-C
10	LNR-2642-AA	End Liner	AA-3-4589-C
11	LNR-2643-A	End Liner	A-3-4590-C
12	LNR-2643-AA	End Liner	AA-3-4590-C
13	LNR-2626-A	End Liner	A-3-4591-C
14	LNR-2626-AA	End Liner	AA-3-4591-C
15	LNR-2627-A	End Liner	A-3-4592-C
16	LNR-2627-AA	End Liner	AA-3-4592-C
17	MXP-7161-A	Mixer Seal	A-3-4426-C
18	MXP-7161-AA	Mixer Seal	AA-3-4426-C

C ONSTRUCTION P ARTS I NC.®



ORDER
BY PHONE

TOLL FREE
1-800-222-1141

Ohio 1-800-338-5608

FAX 216-524-5682

Telephone 216-524-7100



**"The Super Plate
For SUPER Wear"**

The **"ULTIMATE"** For
Chute Liners And High
Abrasive Areas.

STANDARD BARS AND PLATES

(With Countersunk Holes For Bolting Or Plug Welding)

<u>C.P.I. NO.</u>	<u>DESCRIPTION</u>	<u>C.P.I. NO.</u>	<u>DESCRIPTION</u>
STR-111	1 1/4" x 11" x 1/4"	PLT-209	9" x 20 3/4" x 3/4"
STR-218	2" x 18" x 1/2"	PLT-812	8" x 12" x 1/2"
STR-316	3" x 16 3/4" x 1/2"	PLT-820	8" x 19 7/8" x 1/2"
STR-318-3	3" x 18" x 3/8"	PLT-918-3	9" x 18" x 3/8"
STR-318-4	3" x 18" x 1/2"	PLT-918-4	9" x 18" x 1/2"
STR-416	4 3/4" x 16 3/4" x 1/2"	PLT-1218-3	12" x 18" x 3/8"
STR-618-3	6" x 18" x 3/8"	PLT-1218-4	12" x 18" x 1/2"
STR-618-4	6" x 18" x 1/2"		
LNR-2562	3 1/4" x 12 7/8" x 3/4"	<u>CHECK WITH C.P.I. FOR ADDITIONAL SIZES</u>	
LNR-2564	1 3/4" x 23 1/4" x 3/4"		

Also Available-Asphalt Silo Plates

CUSTOMIZED SERVICE/BARS AND PLATES

(To Suit Your Application Or Needs)

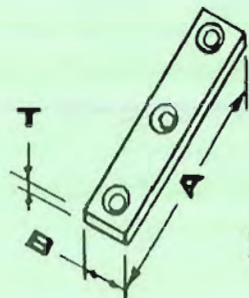

T = Thickness

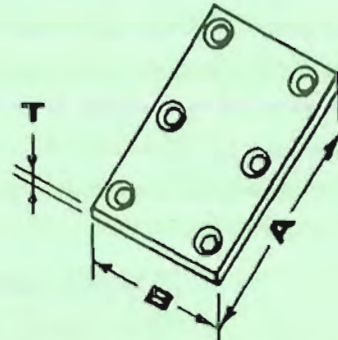
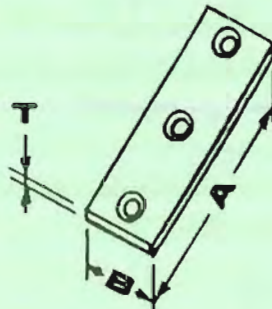

BARS

PLATES

"YOUR HEADQUARTERS FOR ASPHALT PLANT REPLACEMENT PARTS"

C O N S T R U C T I O N P A R T S I N C .[®]



ORDER
BY PHONE

TOLL FREE
1-800-222-1141

Ohio 1-800-338-5608

FAX 216-524-5682

Telephone 216-524-7100

AVAILABLE REPLACEMENT PARTS
FOR
BARBER-GREENE PLANTS

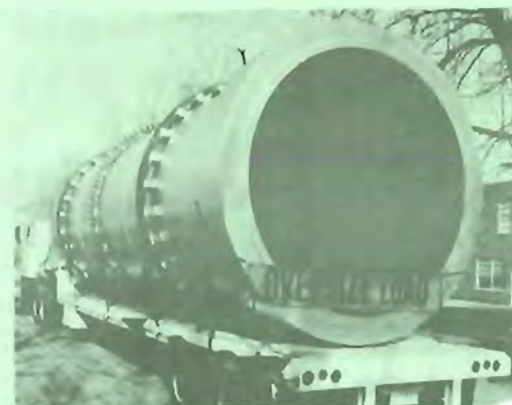

COMPLETE DRYER DRUM REPLACEMENT

C.P.I.

PART No.

PART DESCRIPTION

REPLACEMENT FOR O.E.M. PART No.

DRP-4392	Dryer Drum	A1-835-218W
DRP-4262	Dryer Drum	A1-837-10 WA
DRP-4263	Dryer Drum	A2-837-10 WA
DRP-4264	Dryer Drum	A1-838-10 WA
DRP-4397	Dryer Drum	Model - DA-50
DRP-4417	Dryer Drum	Model - DA-60
DRP-4265	Dryer Drum	Model - DA-65
DRP-4266	Dryer Drum	Model - DA-70
DRP-4267	Dryer Drum	Model - DC-65
DRP-4268	Dryer Drum	Model - DC-70
DRP-4269	Dryer Drum	Model - DC-80

AVAILABLE :

DRYER DRIVE CHAINS AND SPROCKETS !!

"YOUR HEADQUARTERS FOR ASPHALT PLANT REPLACEMENT PARTS"



ORDER
BY PHONE

TOLL FREE
1-800-222-1141

Ohio 1-800-338-5608

FAX 216-524-5682

Telephone 216-524-7100

AVAILABLE REPLACEMENT PARTS
FOR
BARBER-GREENE PLANTS

DRYER FLIGHTS



**Regular
Flight**

**Reinforced
(Leading Edge)
Flight**
Reinforcing Bar
for EXTRA WEAR

**EXTRA THICK
Flight**

RANGE-25% to 100%
thicker over regular
flights.

C.P.I. PART NO. REPLACEMENT FOR
O.E.M. PART NO.

SHORT FLIGHTS

DRP-4054-2	B-829-517
DRP-4056	D-829-559
DRP-4058	E-829-663
DRP-4061-2	D-829-655
DRP-4186	P-838-13
DRP-4187	P1-838-13
DRP-4188	D1-838-13W
DRP-4189	D2-838-13W
DRP-4324	C1-829-226
DRP-4249	J1-837-11
DRP-4250	A1-837-9W
DRP-4414	L-837-11
DRP-4415	A2-837-9W
DRP-4564	C1-829-238
DRP-4581	B-829-517

C.P.I. PART NO. REPLACEMENT FOR
O.E.M. PART NO.

NOTCHED FLIGHTS

DRP-4064	A-829-559W
DRP-4072	B1-829-719W
DRP-4092	B-829-719W
DRP-4194	G1-838-13W
DRP-4195	G2-838-13W
DRP-4252	B1-837-9W
DRP-4255	B-829-662W
DRP-4258	B-829-653W
DRP-4339	A1-829-225W
DRP-4384	C1-829-516W
DRP-4562	C1-829-237W
DRP-4577	B2-837-9W

LONG AND INTERMEDIATE FLIGHTS

DRP-4054-1	A-829-517
DRP-4061-1	C-829-655
DRP-4066	A-829-653W
DRP-4185	C-829-559
DRP-4190	H-838-13
DRP-4191	H1-838-13
DRP-4192	A-829-719
DRP-4193	A1-829-719
DRP-4251	E1-837-9
DRP-4253	A-829-662W
DRP-4254	D-829-663
DRP-4325	B1-829-226
DRP-4340	C1-829-225W
DRP-4403	B-835-216
DRP-4404	C-835-216
DRP-4416	E2-837-9
DRP-4561	A1-829-237W
DRP-4563	B1-829-238

KICKER FLIGHTS

DRP-4073	F-829-662W
DRP-4243	D-837-9
DRP-4244	F-838-14
DRP-4245	F1-829-225W
DRP-4405	J-835-219W
DRP-4406	D-835-216
DRP-4560	E1-829-237W
DRP-4578	L-837-9W

ANGLE FLIGHTS

DRP-4053	E-829-516
DRP-4246	A-829-655
DRP-4247	B-829-655
DRP-4248	C1-837-9
DRP-4401	A1-835-216
DRP-4402	A-835-216

DRUM MIX FLIGHTS

DRP-4503	BF-829-2683
DRP-4504	DA-829-2682W
DRP-4506	CA-829-2273
DRP-4508	BD-2683
DRP-4510	CB-2273
DRP-4512	FA-2272W
DRP-4513	AE-2303
DRP-4514	BB-829-2273
DRP-4484	E-829-1117
DRP-4485	C-829-1117
DRP-4486	F-829-1117
DRP-4487	J-829-1117

DRYER TRUNNIONS

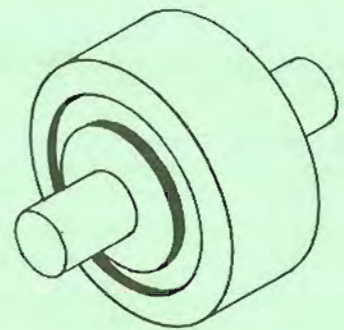
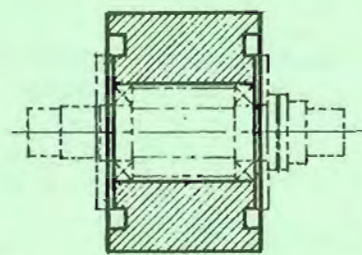

TRUNNION ROLLER

TRUNNION ROLLER ASS'Y

**C.P.I.
PART No.**

PART DESCRIPTION

**REPLACEMENT FOR
O.E.M. PART No.**

DRP-4574	Trunnion Roller	B-3-1100-C (#1502)
DRP-4452	Trunnion Roller	B-3-2788-C
DRP-4463	Trunnion Roller	B-3-3484-C
DRP-4464	Trunnion Roller	B-3-2227-C (#4596)
DRP-4662	Trunnion Roller	AB-829-2558

TRUNNION ROLLER ASSEMBLY

DRP-4456	Trunnion Roller Ass'y	DA-50 Dryer
DRP-4358	Trunnion Roller Ass'y	DA-55 Dryer
DRP-4465	Trunnion Roller Ass'y	DA-60 Dryer
DRP-4430	Trunnion Roller Ass'y	837 Dryer (#4167)
DRP-4327	Trunnion Roller Ass'y	C-3-4242-C E-3-1547-C
DRP-4434	Trunnion Roller Ass'y	B-3-3775-C (P-3-1300-C) (#4134)
DRP-4465	Trunnion Roller Ass'y	G-3-1547-C A-829-432
DRP-4609	Trunnion Roller Ass'y	CA-829-1587W



ORDER
BY PHONE

TOLL FREE
1-800-222-1141

Ohio 1-800-338-5608

FAX 216-524-5682

Telephone 216-524-7100

AVAILABLE REPLACEMENT PARTS
FOR
BARBER-GREENE PLANTS

SPROCKETS/CHAINS

DRYER DRUM - SEGMENTAL SPROCKETS

C.P.I. PART No.	REPLACEMENT FOR O.E.M. PART No.	C.P.I. PART No.	REPLACEMENT FOR O.E.M. PART No.
TRP-373	A-19-2124	TRP-409	A-829-660W
TRP-374	A-19-2065	TRP-410	A-19-2118
TRP-376	A-19-2186	TRP-419	A-829-652W
TRP-379	E-837-14W	TRP-387	A-829-234W
TRP-368	A-835-219W	TRP-399	A-839-28WA
TRP-407	A-19-2174	TRP-426	A-829-222W



DRIVE & IDLER SPROCKETS

C.P.I. PART No.	REPLACEMENT FOR O.E.M. PART No.	C.P.I. PART No.	REPLACEMENT FOR O.E.M. PART No.
TRP-362-A	A-19-1957W	TRP-389-A	A-19-1958W
TRP-363-A	A-19-1756W	TRP-429	DA-65 Dryer
TRP-364-A	A-19-2278W	TRP-430	DA-65 Dryer
TRP-365-A	A-19-1904W	TRP-431	A-19-1755W
TRP-366-A	A-19-1959W	TRP-467	A-19-2123W
TRP-367-A	A-19-1605W	TRP-468	A-19-1403W
TRP-377-A	A-19-886W	TRP-469	A-19-1353W
TRP-384	A-19-2208W	TRP-470	A-19-2330W
TRP-385-A	A-19-990W	TRP-471	A-19-2331W



**SPLINED SPROCKET
(Shown)**

DRYER - DRIVE CHAINS

C.P.I. PART No.	PART DESCRIPTION	REPLACEMENT FOR O.E.M. PART No.
DCH-1052-Z	Drive Chain	10Z52
DCH-1155-A	Drive Chain	11A55
DCH-1300-F	Drive Chain	13F00
DCH-1400-S	Drive Chain	14S00
DCH-1400-X	Drive Chain	14X00
DCH-1200-F	Drive Chain	12F00
DCH-1400-Y	Drive Chain	14Y00

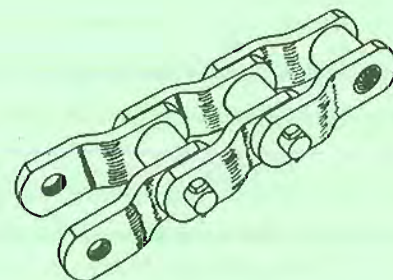

DRIVE CHAIN

"YOUR HEADQUARTERS FOR ASPHALT PLANT REPLACEMENT PARTS"

C O N S T R U C T I O N P A R T S I N C .[®]



ORDER
BY PHONE

TOLL FREE
1-800-222-1141
OHIO CALLS 216-524-7100

AVAILABLE REPLACEMENT PARTS FOR BARBER-GREENE PLANTS

TRUNNION RINGS (DRYER TIRES)

C.P.I.
PART No.

PART DESCRIPTION

DRP-4278	Trunnion Ring
DRP-4279	Trunnion Ring
DRP-4280	Trunnion Ring
DRP-4281	Trunnion Ring
DRP-4282	Trunnion Ring
DRP-4283	Trunnion Ring
DRP-4284	Trunnion Ring
DRP-4285	Trunnion Ring
DRP-4286	Trunnion Ring
DRP-4287	Trunnion Ring

**REPLACEMENT FOR
O.E.M. PART No.**

AL-837-13W
A-837-12W
C-829-651
AL-829-651W
A-829-558
A-829-558W
A-829-560
A-829-661W
C-838-12
C-838-12W

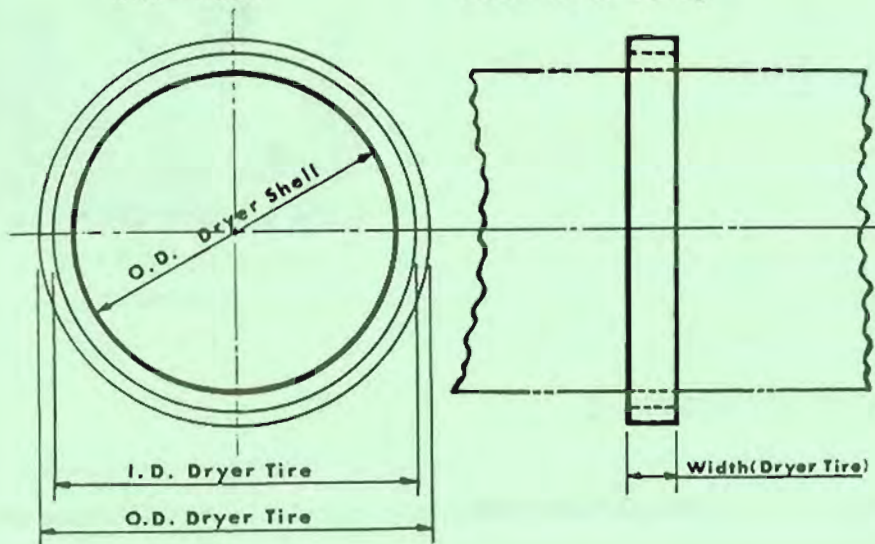

IMPORTANT!

DRYER TIRES furnished by **C.P.I.**
will be made from High Quality
FORGED SEAMLESS STEEL.
Machined to $\pm 1/16$ " Tolerance.
FINISH ALL OVER

To Obtain Quote....
(Need following information)

- _____ O.D. Dryer Tire
- _____ I.D. Dryer Tire
- _____ Width (Dryer Tire)

TRUNNION SADDLES

DRP-4294	Trunnion Saddles
DRP-4295	Trunnion Saddles
DRP-4296	Trunnion Saddles
DRP-4297	Trunnion Saddles
DRP-4298	Trunnion Saddles
DRP-4299	Trunnion Saddles
DRP-4300	Trunnion Saddles

**REPLACEMENT FOR
O.E.M. PART No.**

D-837-13W
D1-837-13W
B-829-651W
E-829-12W
B-829-560
E-829-662W
D-829-664

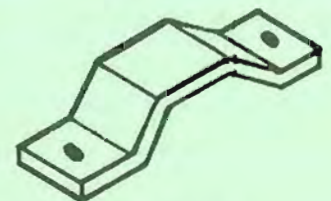

"YOUR HEADQUARTERS FOR ASPHALT PLANT REPLACEMENT PARTS"

CONSTRUCTION PARTS INC.®



ORDER
BY PHONE

TOLL FREE
1-800-222-1141

Ohio 1-800-338-5608

FAX 216-524-5682

Telephone 216-524-7100

**AVAILABLE REPLACEMENT PARTS
FOR
BARBER-GREENE PLANTS**

**DRYER SEALS
& BRACKETS**

SEAL SUPPORT BRACKETS

C.P.I. PART No.	PART DESCRIPTION	REPLACEMENT FOR O.E.M. PART No.
DRP-4449	L.H. Bracket Ass'y	A-829-798-AL (M-837-552-WL)
DRP-4450	R.H. Bracket Ass'y	A-829-798-AR (M-837-552-WR)



DRYER SEALS

C.P.I. PART No.	PART DESCRIPTION	REPLACEMENT FOR O.E.M. PART No.
DRP-4375-A	Seal	A-3-3368-C #5021
DRP-4375-B	Seal	B-3-3368-C
DRP-4376-A	Seal	A-3-3369-C #5022
DRP-4376-B	Seal	B-3-3369-C
DRP-4390-A	Seal	A-3-3370-C #5023
DRP-4390-B	Seal	B-3-3370-C
DRP-4469	Seal	A-3-3412-C #5040
DRP-4568	Seal	A-3-3410-C #5039
Check w/CPI	Seal	B-3-3146-C #4934 (B-3-3368-C)
Check w/CPI	Seal	B-3-3369-C #4935 (F/2-4935)
Check w/CPI	Seal	B-3-3370-C #4954
DRP-4705	Seal	B-3-3285-C
DRP-4706	Seal	B-3-3289-C

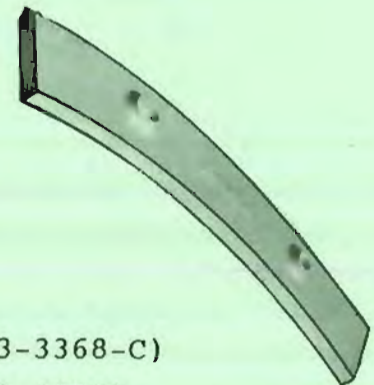

"YOUR HEADQUARTERS FOR ASPHALT PLANT REPLACEMENT PARTS"

Replacement For.....
GENCO IGNITION CONES

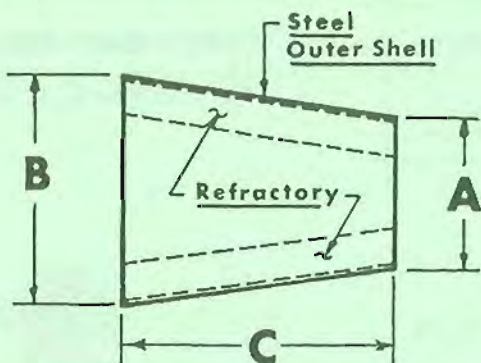

<u>C.P.I.</u> <u>PART NO.</u>	<u>GENCO</u> <u>BURNER SIZE</u>	<u>PORT</u> <u>SIZE</u>
DRP-4146	FP-40, 51, 69	K-20
DRP-4147	FP-86	K-21
DRP-4148	FP-103, 129	K-22
DRP-4149	FP-162	K-23
DRP-4150	FP-202	K-24
DRP-4151	FP-248	K-25
DRP-4152	#301/#401/#501/#601	
DRP-4153	#751/#1001/#1251	

<u>C.P.I.No.</u>	<u>A</u>	<u>B</u>	<u>C</u>
DRP- 4146	17½	26	37
DRP- 4147	20½	30	37
DRP- 4148	23	33	37
DRP- 4149	25¼	36	37
DRP- 4150	25¼	39	37
DRP- 4151	29¼	43	37
DRP- 4152	20½	34	37
DRP- 4153	25¼	39	37

CONSTRUCTION OF IGNITION CONE

Outer shell to be 3/16" Thick Steel.
Lining will be of "High Temperature"
Super Duty Castable Refractory anchored
to shell with stainless steel V-anchors.

CUSTOMIZED -IGNITION CONES

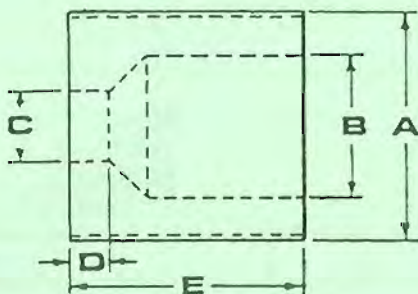

STRAIGHT CONE

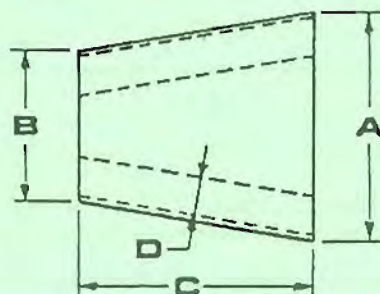

TAPERED CONE

DIMENSIONS NEEDED FROM YOU TO OBTAIN QUOTE

- A ___ OUTSIDE DIAMETER
- B ___ INSIDE DIAMETER
- C ___ INSIDE DIAMETER
- D ___ DEPTH
- E ___ OVERALL LENGTH

- A ___ MAX. DIAMETER
- B ___ MIN. DIAMETER
- C ___ OVERALL LENGTH
- D ___ THICKNESS
(Refractory)

IGNITION CONES
COMBUSTION CHAMBERS

IGNITION CONES

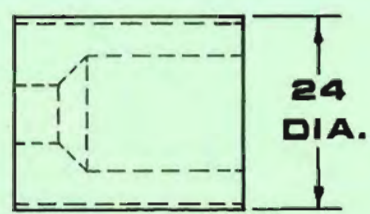

Hauck No. JLP-4250
DRP-4554

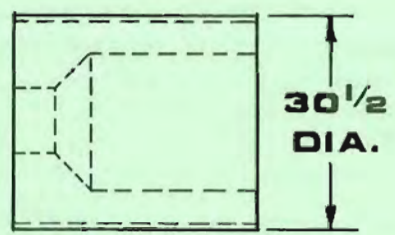

Hauck No. JB-500
B/G No. HA-31420
DRP-4546

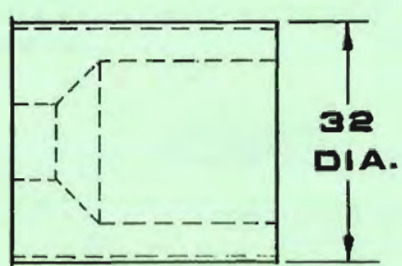

Hauck No. J-375-5000
DRP-4443

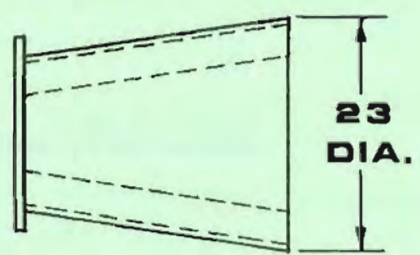

Replacement For
Dryer Model 837
DRP-4256

COMBUSTION CHAMBERS



B/G No. A-829-697-B
DRP-4545



B/G No. A-829-947-W
DRP-4445

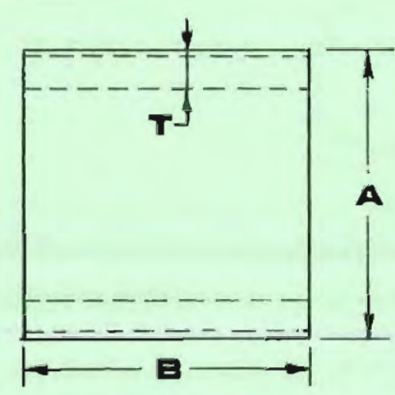

Dimensions Needed From You
To Obtain Quote.....

- A _____ Outside Diameter
- B _____ Overall Length
- T _____ Thickness (Refractory)



ORDER
BY PHONE

TOLL FREE
1-800-222-1141

Ohio 1-800-338-5608

FAX 216-524-5682

Telephone 216-524-7100

AVAILABLE REPLACEMENT PARTS
FOR
BARBER-GREENE PLANTS

DRYER DRUM
ROTARY CHUTES
LINERS & SPROCKETS

ROTARY CHUTES

DRP-4467
REPLACEMENT FOR
O.E.M. PART NO.
A-837-518W

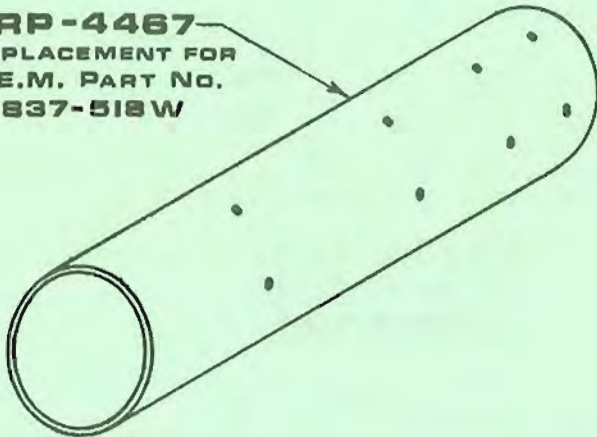

DRP-4468
REPLACEMENT FOR
O.E.M. PART NO.
A-829-926W

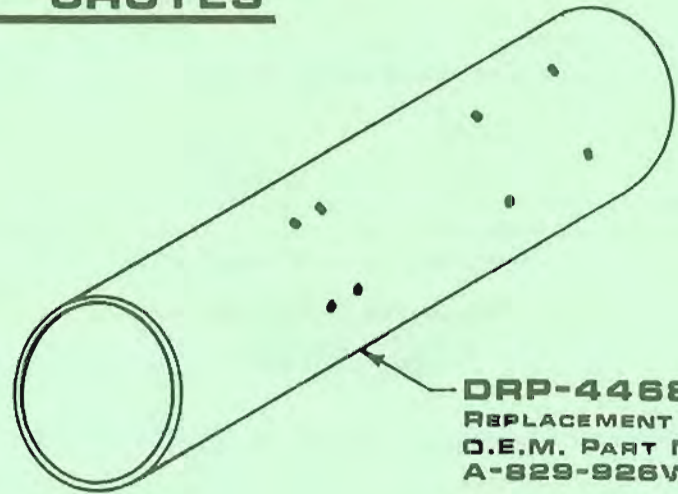

ROTARY CHUTE LINERS

DRP-4391-C3
REPLACEMENT FOR
O.E.M. PART NO.
AC-829-983

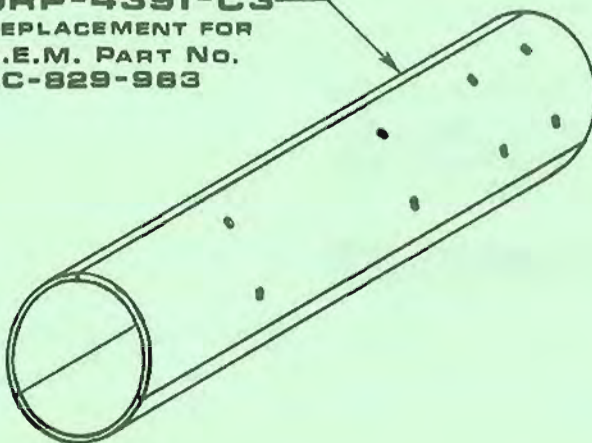

DRP-4473-AA
REPLACEMENT FOR
O.E.M. PART NO.
AA-829-983

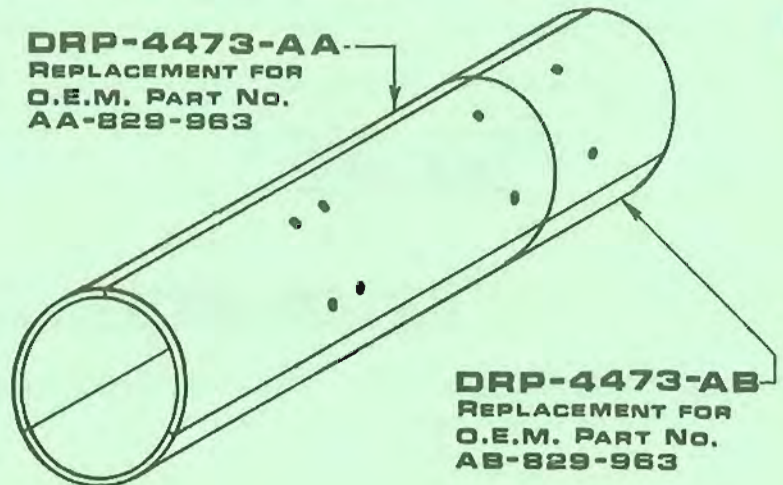

DRP-4473-AB
REPLACEMENT FOR
O.E.M. PART NO.
AB-829-983

DRYER CHUTE LINERS

C.P.I. PART No.	REPLACEMENT FOR O.E.M. PART No.
DRP-4488-A	A-837-567
DRP-4488-C	C-837-567
DRP-4488-BR	B-837-567-R
DRP-4488-BL	B-837-567-L
DRP-4488-DR	D-837-567-R
DRP-4488-DL	D-837-567-L

ROTARY CHUTE SPROCKET

C.P.I. PART No.	REPLACEMENT FOR O.E.M. PART No.
TRP-472	A-19-2000W (A-19-1685W)
TRP-473	A-19-2001W (A-19-1679W)

"YOUR HEADQUARTERS FOR ASPHALT PLANT REPLACEMENT PARTS"



ELEVATOR Sprockets/Traction Wheels

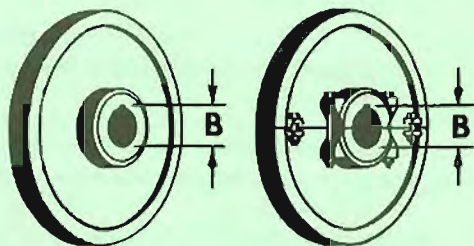

TRACTION WHEELS
Solid Type Split Type

TRACTION WHEELS
COMPLETE W/HUB
(Including Standard Keyway
And Set Screws)

Information Required
To Quote.....

Solid Type _____ Split Type _____
Wheel Diameter _____
Chain Size _____
Bore Diameter "B" _____
(Shaft Diameter)

SPROCKETS
To Order, Specify

No. Of Teeth _____
Chain Size _____
(3) Segments _____
or
(4) Segments _____
Bore Diameter "B" _____
(Shaft Diameter)

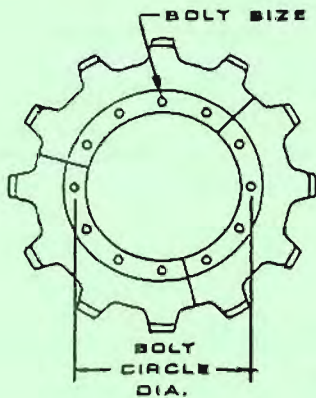

(3) SEGMENTS



SEGMENTAL SPROCKETS

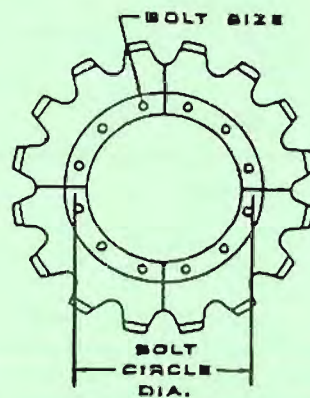

(4) SEGMENTS

SPROCKET PART NO.	TRACTION WHEEL PART NO.	HUB BODY NO.	BOLT CIRCLE DIAMETER	BOLT SIZE	A	C	D	E
TRP-1010	ETW-1010	CPI-1010	10	1/2	8-1/2	5/8	12-1/4	11-3/4
TRP-1212	ETW-1212	CPI-1212	12	5/8	10-1/2	3/4	14-1/4	13-3/4
TRP-1616	ETW-1616	CPI-1616	16	3/4	14-1/2	3/4	18-1/4	17-3/4
TRP-2020	ETW-2020	CPI-2020	20	3/4	18-1/2	7/8	22-1/4	21-3/4
TRP-2525	ETW-2525	CPI-2525	25	1	23	1	28-1/4	27-3/4

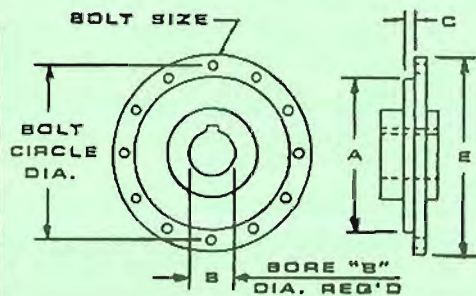

BODY HUB
Sprocket/Traction Wheel

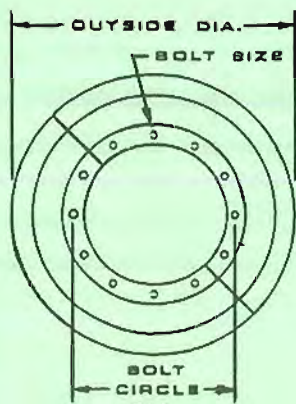

(2) SEGMENTS

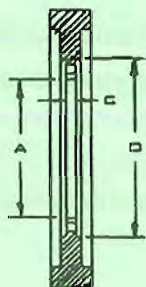

SEGMENTAL TRACTION WHEELS

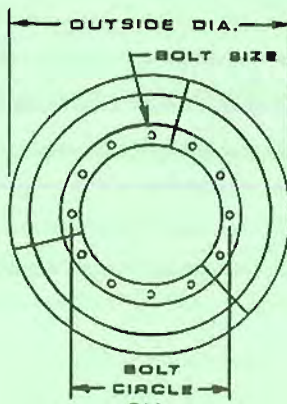

(3) SEGMENTS

TRACTION WHEELS
To Order, Specify

Outside Dia. _____
Chain Size _____
(2) Segments _____
or
(3) Segments _____
Bore Diameter "B" _____
(Shaft Diameter)



ELEVATOR Sprockets

C.P.I. PART NO.	PART DESCRIPTION	REPLACEMENT FOR O.E.M. PART NO.
TRP-474	8 Tooth Sprocket	C-19-735-C (#2994-A)
TRP-475	8 Tooth Sprocket	D-19-735-C (#2994-B)
TRP-476	8 Tooth Sprocket	F-19-735-C (#2994-D)
TRP-477	12 Tooth Sprocket	C-19-877-C (#3637-A)
TRP-478	11 Tooth Sprocket	B-19-891-C
TRP-479	11 Tooth Sprocket	C-19-891-C (#3975-A)
TRP-480	11 Tooth Sprocket	D-19-891-C (#3975-B)
TRP-481	11 Tooth Sprocket	E-19-891-C (#3975-C)
TRP-482	11 Tooth Sprocket	F-19-891-C (#3975-D)
TRP-483	13 Tooth Sprocket	B-19-1968-C (#5202) (#4463)
TRP-484	13 Tooth Sprocket	C-19-1968-C
TRP-485	13 Tooth Sprocket	D-19-1968-C
TRP-486	13 Tooth Sprocket	E-19-1968-C
TRP-487	13 Tooth Sprocket	F-19-1968-C
TRP-488	11 Tooth Sprocket	C-19-2098-C
TRP-489	13 Tooth Sprocket	B-19-2226-C

CUSTOMIZED STEEL SPROCKETS

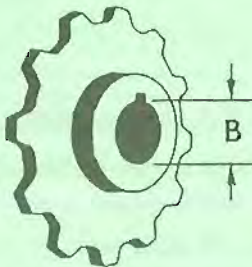

**CHAIN
SPROCKET**
(Split Type)
Not Shown

CHAIN SPROCKET
Solid Type
COMPLETE W/HUB
(Including Standard Keyway
And Set Screws)

Information Required To Quote

Number Of Teeth _____

Chain Size _____

Bore Diameter "B" _____
(Shaft Diameter)

Solid Type _____ Split Type _____



ORDER
BY PHONE

TOLL FREE
1-800-222-1141

Ohio 1-800-338-5008

FAX 216-524-5682

Telephone 216-524-7100

AVAILABLE REPLACEMENT PARTS
FOR
BARBER-GREENE PLANTS

**ELEVATOR
BUCKETS/CHAINS**

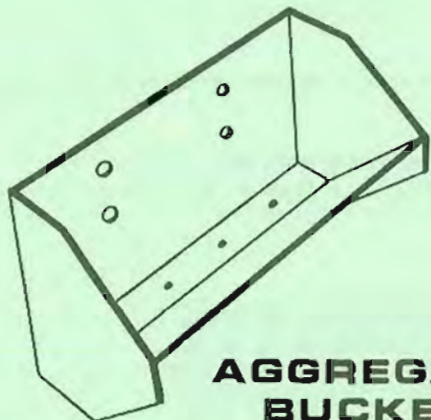

**AGGREGATE
BUCKET**

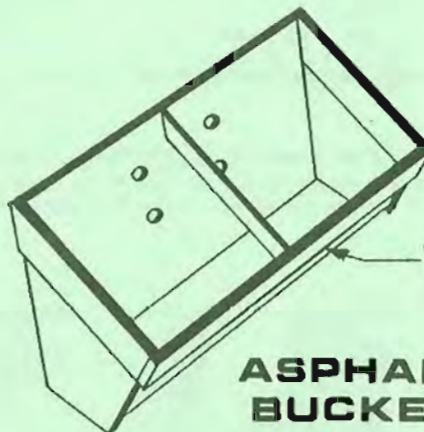

**A.R.S.
Wear Bars
(3 Sides)**

**ASPHALT
BUCKET**

ELEVATOR BUCKETS

C.P.I. PART No.	REPLACEMENT FOR O.E.M. PART No.	C.P.I. PART No.	REPLACEMENT FOR O.E.M. PART No.	C.P.I. PART No.	REPLACEMENT FOR O.E.M. PART No.
HEB-5028	L-3-2395-W	HEB-5036	A-3-2610-W	HEB-5052	A-3-4622-W
HEB-5029(ET)	L-3-2395-W	HEB-5037(ET)	A-3-2610-W	HEB-5055	A-3-4627-W
HEB-5031(ET)	K-3-2395-W	HEB-5041	A-3-4573-W	HEB-5056	A-3-4626-W
HEB-5034	G-3-2395-W	HEB-5042(ET)	A-3-4573-W	HEB-5066	B1-3-1518-W
HEB-5035(ET)	G-3-2395-W	HEB-5053(ET)	C-3-4573-W	HEB-5067	A-3-2349-W
HEB-5046	D-3-2395-W	HEB-5043	A1-3-1680-W	HEB-5068	A-3-2395-W
HEB-5047(ET)	D-3-2395-W	HEB-5044(ET)	A1-3-1680-W		

(ET) Denotes "EXTRA THICK" Elevator Buckets

SILO CHAIN

C.P.I. PART No.	REPLACEMENT FOR O.E.M. PART No.
SCH-2652-L	26L52
SCH-1648-W	16W48

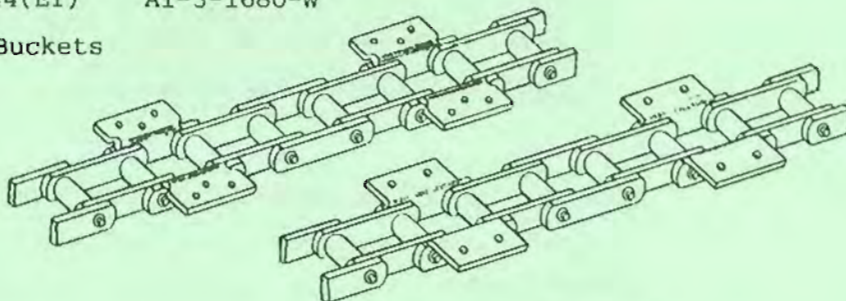

ELEVATOR CHAIN

C.P.I. PART No.	REPLACEMENT FOR O.E.M. PART No.
ECH-1013-V	10V13
ECH-1120-H	11H20
ECH-1140-H	11H40
ECH-1160-J	11J60
ECH-1100-W	11W00
ECH-1200-Z	12Z00
ECH-1400-B	14B00

ELEVATOR CHAIN

C.P.I. PART No.	REPLACEMENT FOR O.E.M. PART No.
ECH-1160-H	11H60
ECH-1180-H	11H80
ECH-1180-W	11W80
ECH-1300-H	13H00
ECH-1449-H	14H49
ECH-1520-A	15A20
ECH-2652-L	26L52

"YOUR HEADQUARTERS FOR ASPHALT PLANT REPLACEMENT PARTS"

CONSTRUCTION **P**ARTS **I**NC.®



ORDER
BY PHONE

TOLL FREE
1-800-222-1141

Ohio 1-800-338-5608

FAX 216-524-5682

Telephone 216-524-7100

ANOTHER INSTALLATION !!

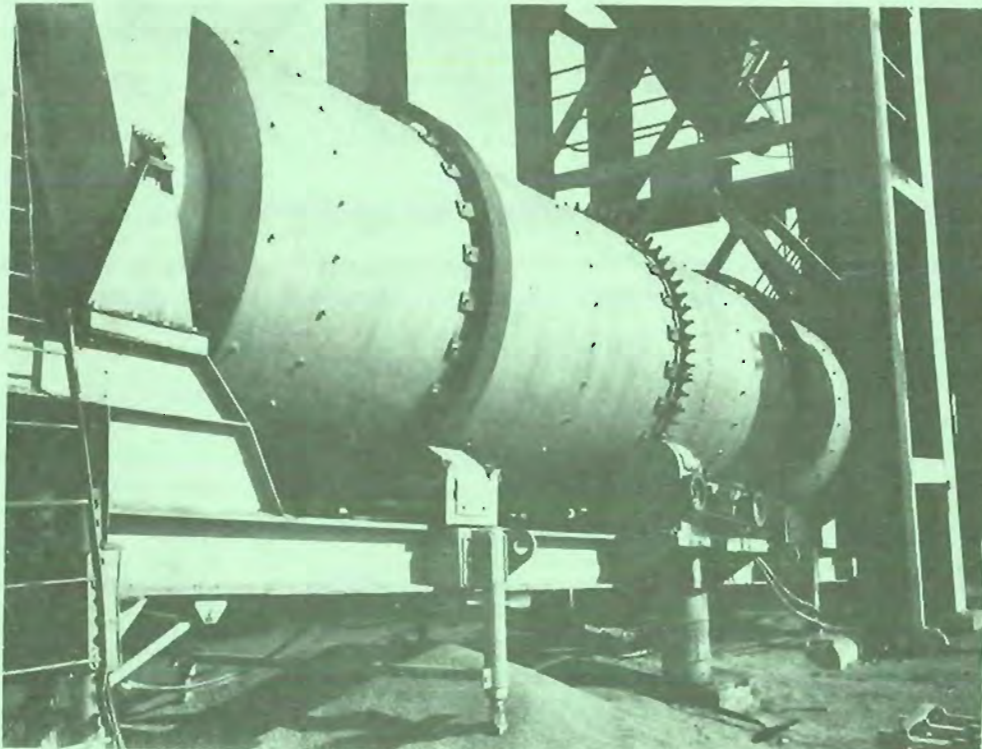

**ABOVE SHOWN REPLACEMENT DRYER SHELL WITH
ROTARY ELEVATOR FURNISHED BY CONSTRUCTION
PARTS, INC. RE-USING TRUNNION RINGS
SPROCKET AND FLIGHTS.**

**CONSTRUCTION PARTS INC. CAN FURNISH
DRYER SHELL REPLACEMENTS IN MANY WAYS IN ORDER
TO "SAVE YOU MONEY"**

AVAILABLE :

- DRYER DRIVE CHAINS AND SPROCKETS
- DRYER DRIVE GEARS
- IGNITION CONES

"YOUR HEADQUARTERS FOR ASPHALT PLANT REPLACEMENT PARTS"